

OPM045

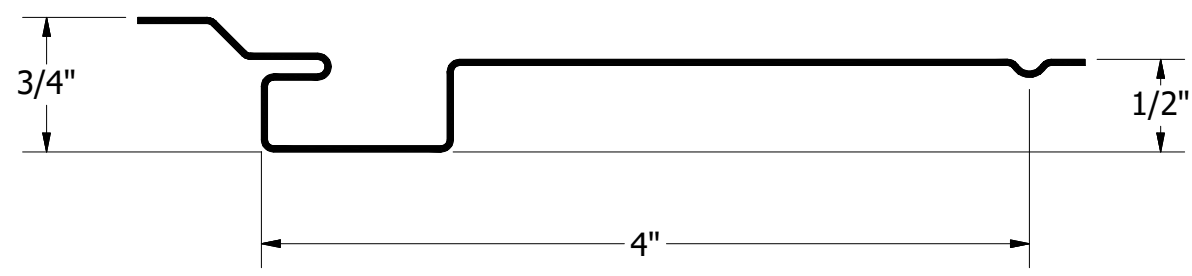

OPN041

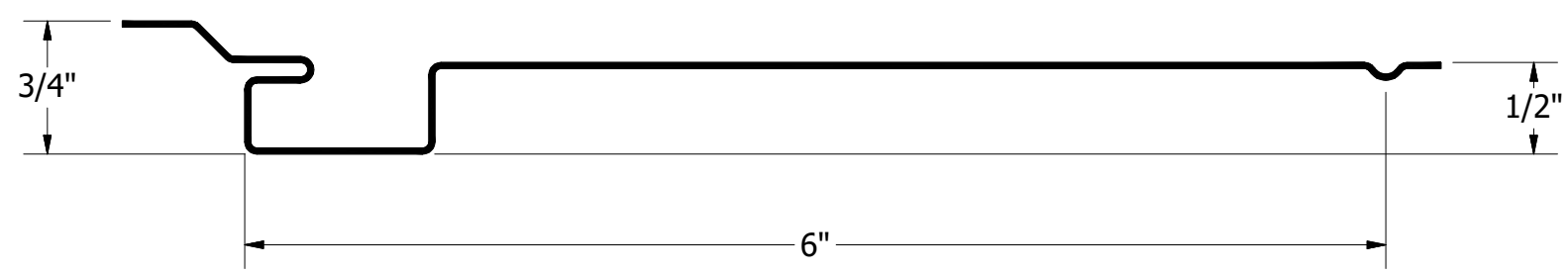

OPN061

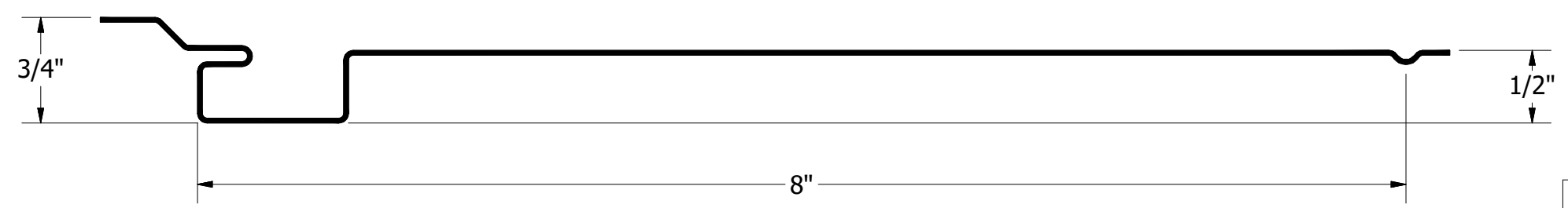

OPN081

Note: * denotes color side.

REV. NO.		DATE		DESCRIPTION OF REVISION		BY		APP			
TITLE								OPN, OPM Panel Profile Detail			
DWG. NO.								DR	KRK	DATE	8/20/2024
MATERIAL								APP		DATE	
								SH. SIZE	B	SCALE	X:X

ATAS INTERNATIONAL, INC
 Allentown PA
 610-395-8445
 Mesa AZ
 480-558-7210

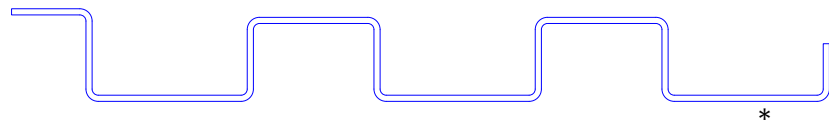

OPM045 Splice Plate

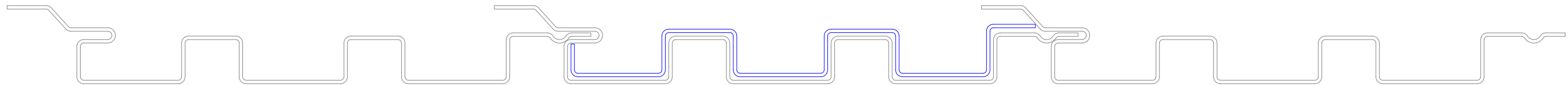
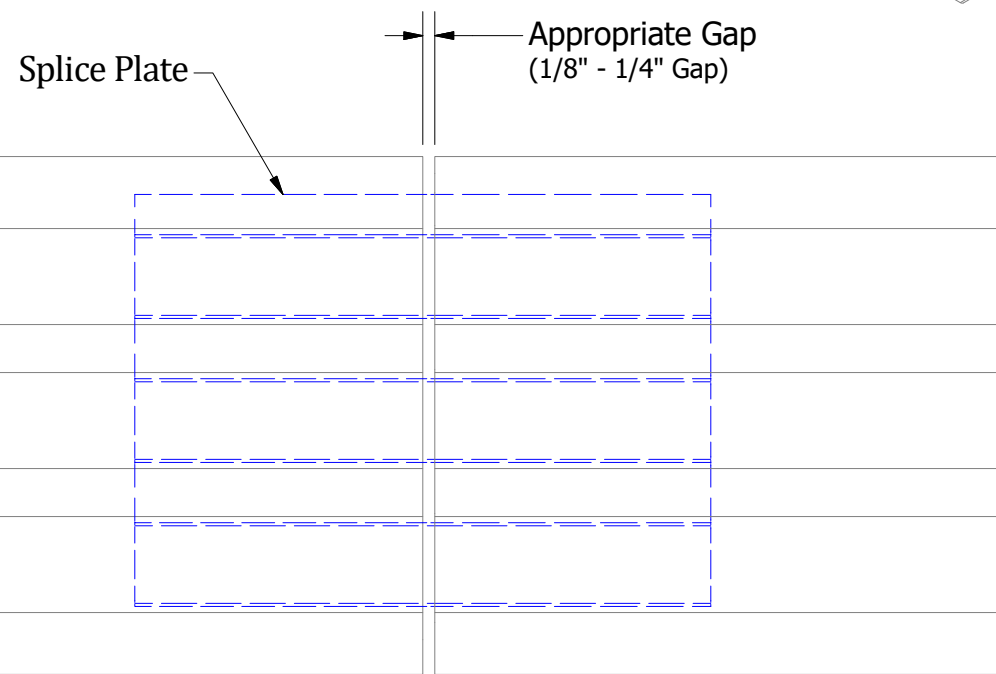
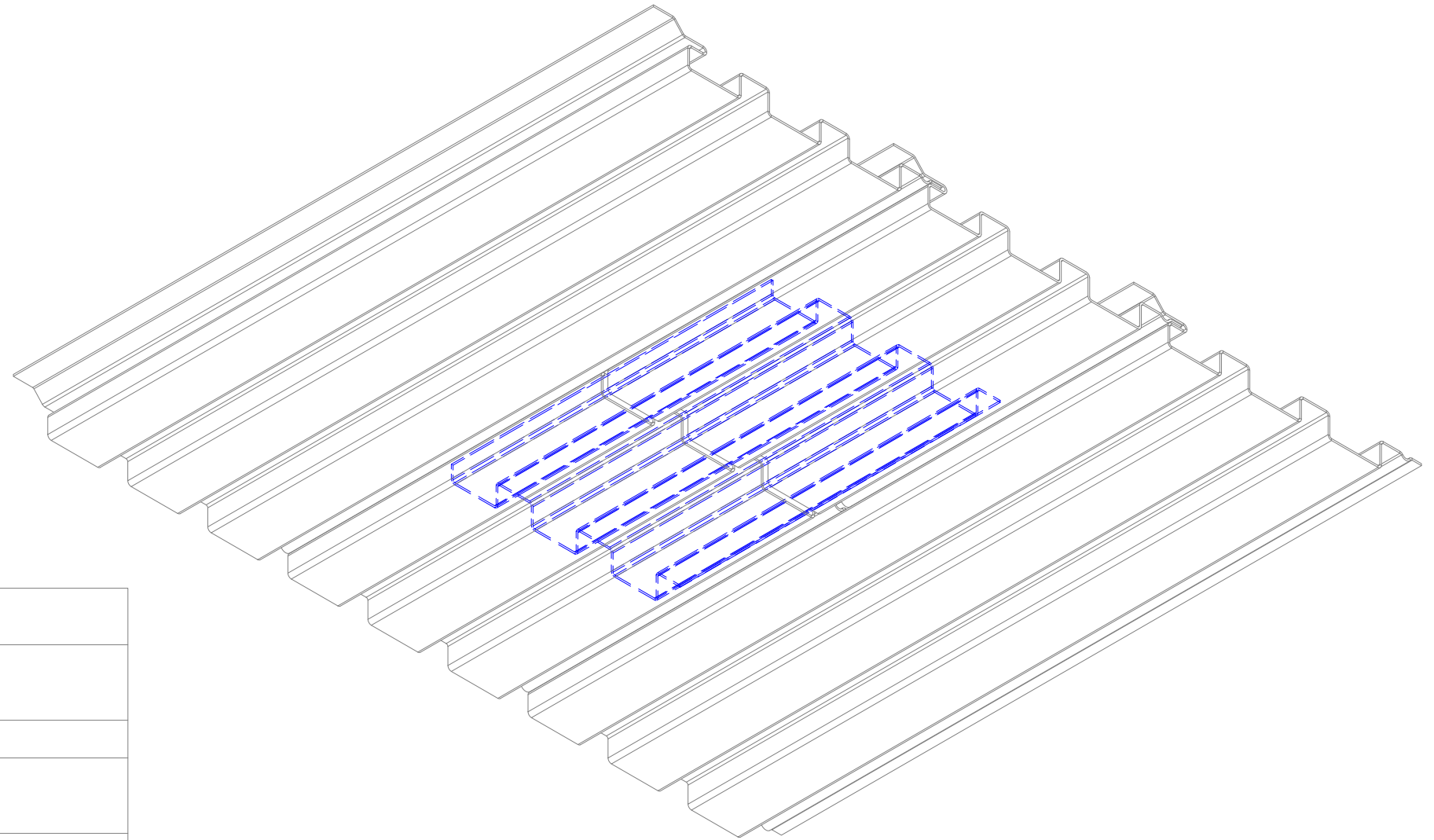

Notes:

1) * denotes color side.

ATAS International, Inc.
 Sustainable Solutions For A Better Future
 www.atas.com | info@atas.com
 800.468.1441

REV. NO.		DATE	DESCRIPTION OF REVISION	BY	APP	DWG TITLE: Splice Assembly		DWG No.:		DWG DATE:
1	4/29/2026		Removed Butyl Sealant, Pop Rivet and Notes. Revised drawing onto new template	M.L.P.	D.S.	DWG No.:		K.R.K.	8/20/2024	
0	8/20/2024		Initial Release	K.R.K.	D.S.	DWG No.:		D.S.	8/20/2024	
PANELS/PRODUCT:						(OPM) Opaline™		SHEET SIZE: B		SCALE: X : X

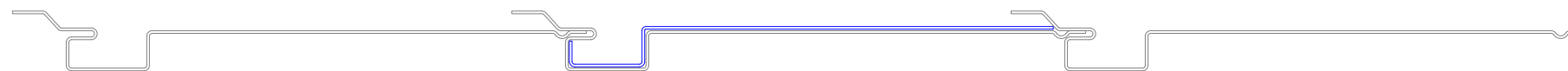
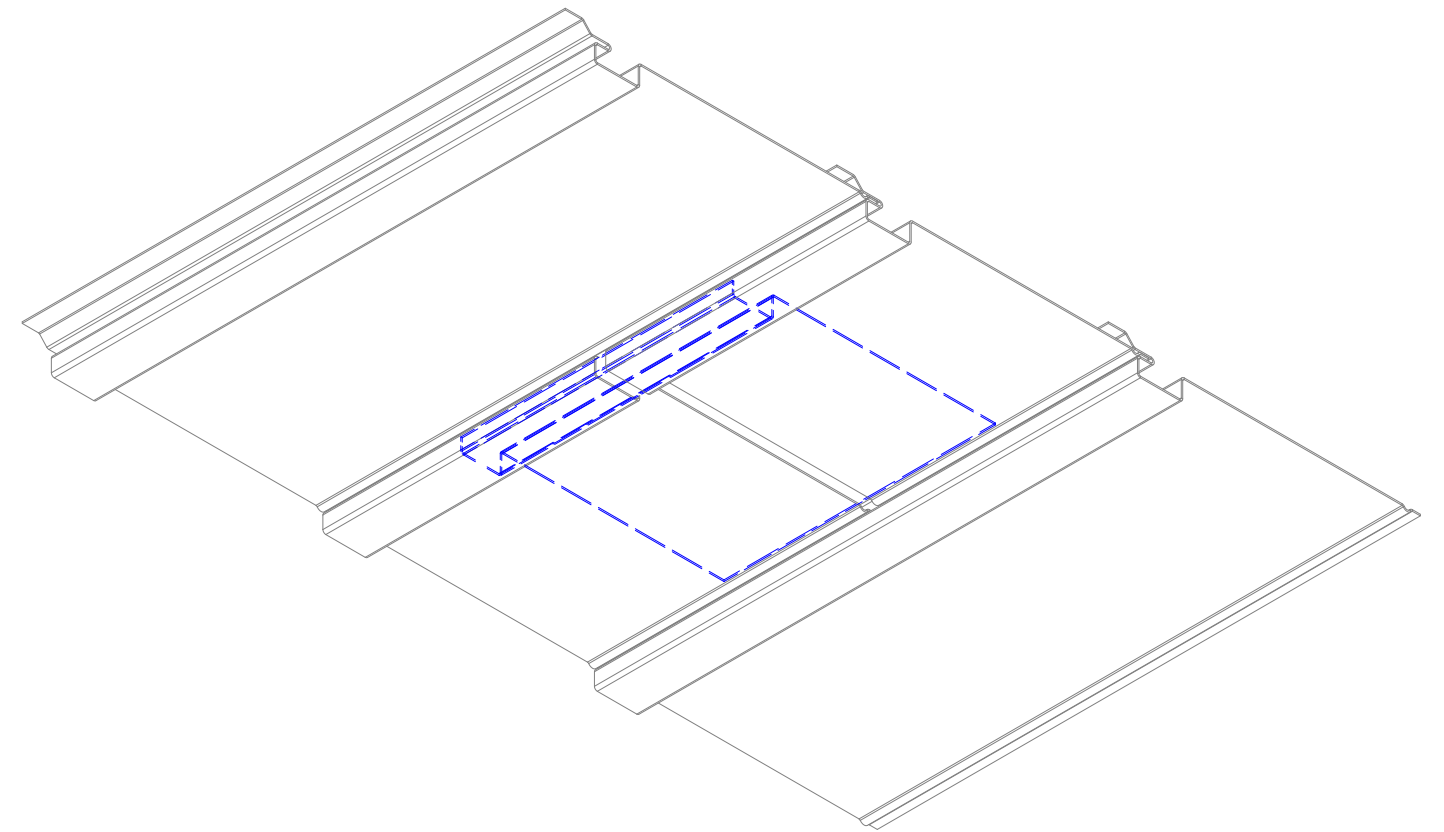
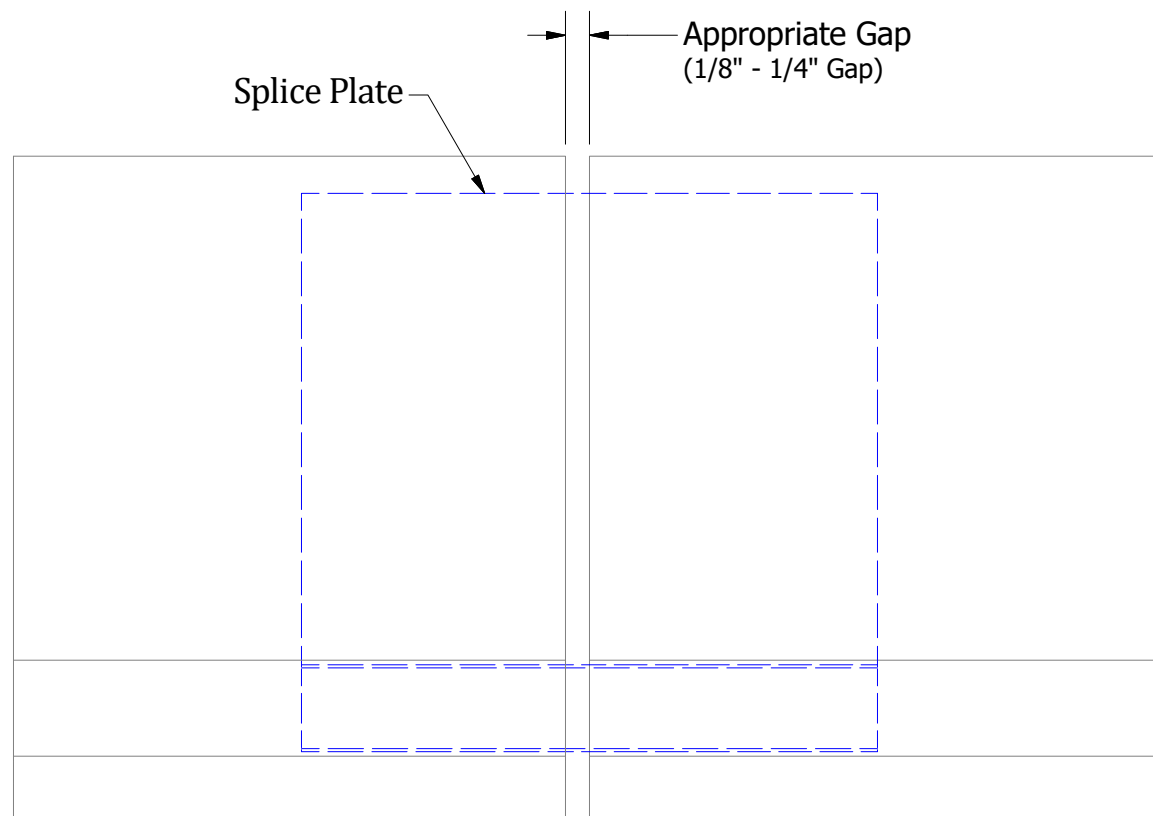

OPN Splice Plate

Notes:

1) * denotes color side.



DWG TITLE:		Splice Assembly	
REV. NO.	DATE	DESCRIPTION OF REVISION	BY APP
1	4/29/2026	Removed VHB tape, Butyl Sealant and Notes. Revised drawing onto new template	M.L.P. D.S.
0	8/20/2024	Initial Release	K.R.K. D.S.
DWG No:		DWG DATE: 8/20/2024	
APP BY:		APP DATE: 8/20/2024	
PANELS/PRODUCT:		(OPN) Opaline™	
SHEET SIZE: B		SCALE: X : X	

REV. NO.	DATE	DESCRIPTION OF REVISION	BY	APP
1	4/29/2026	Removed VHB tape, Butyl Sealant and Notes. Revised drawing onto new template	M.L.P.	D.S.
0	8/20/2024	Initial Release	K.R.K.	D.S.

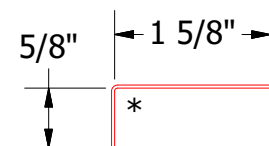
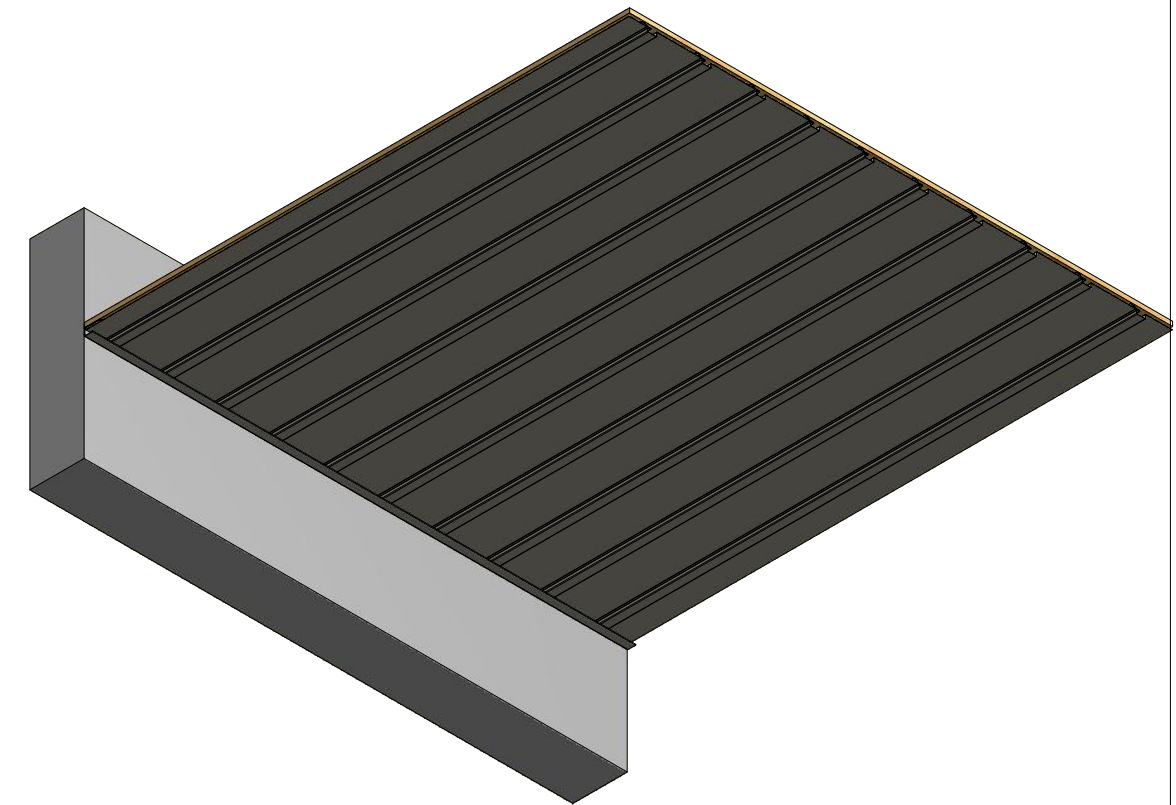
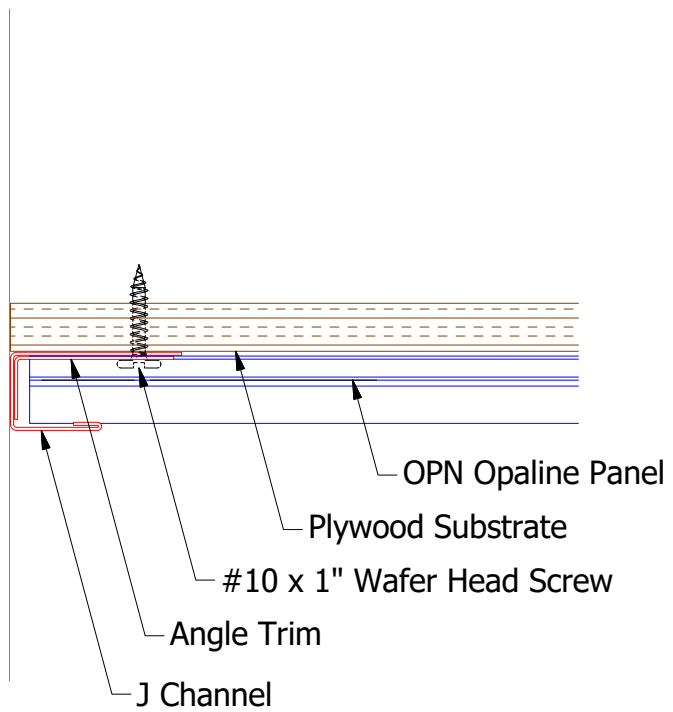
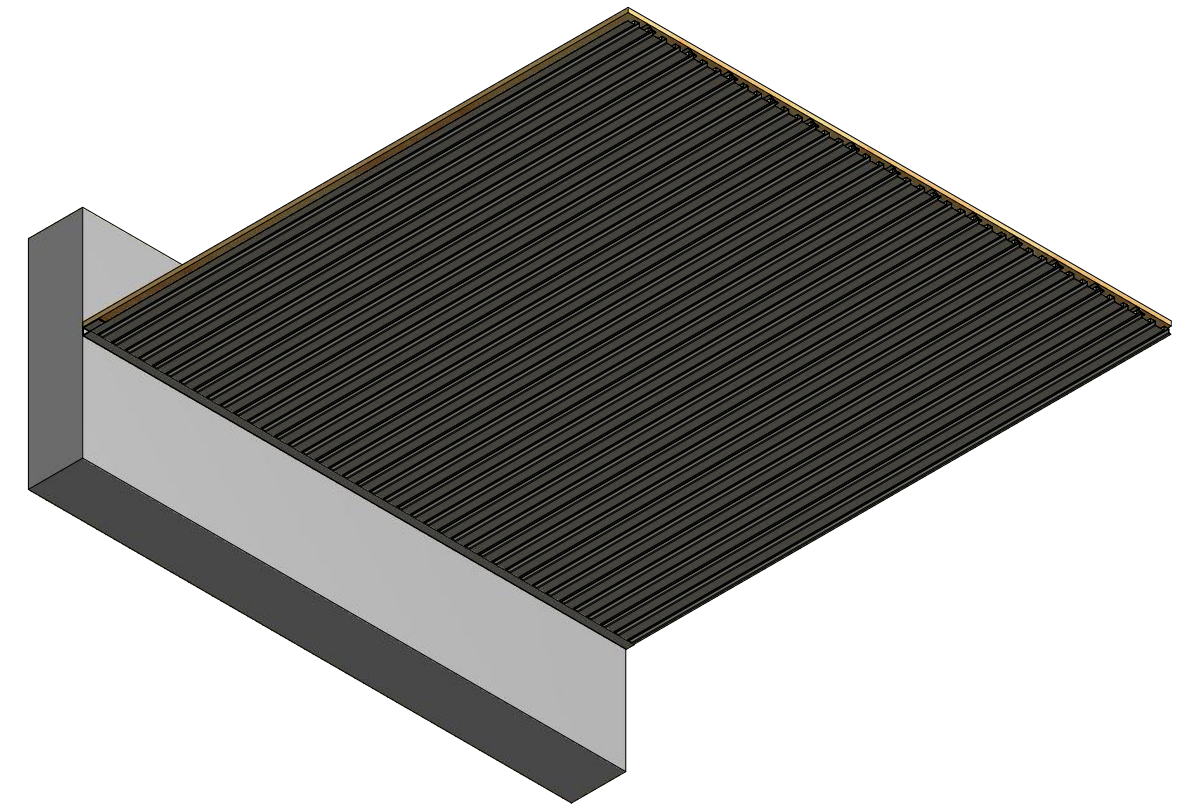
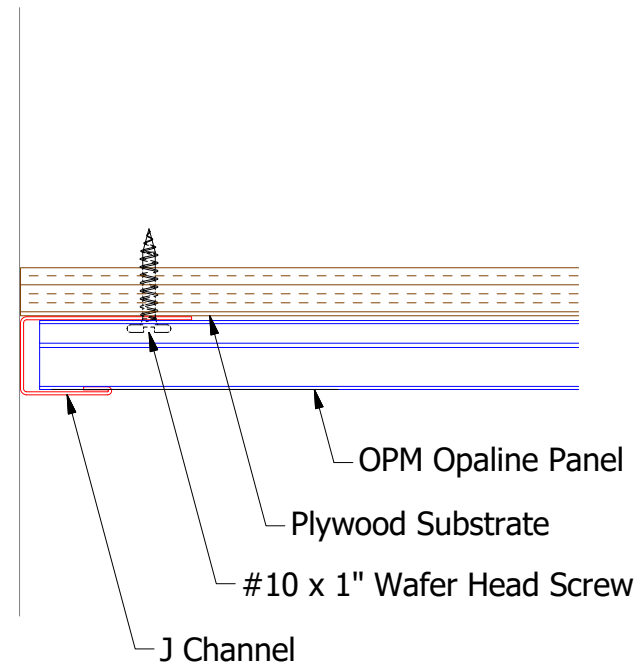

OPA680 - Angle Trim

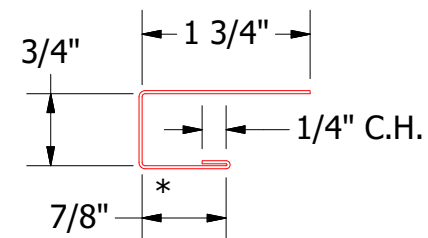

OPA034 - J Channel

Note: * denotes color side.

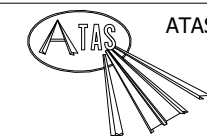

ATAS INTERNATIONAL, INC
Allentown PA
610-395-8445
Mesa AZ
480-558-7210

TITLE		OPN, OPM Endwall Detail	
DWG. NO.	DR	DATE	8/20/2024
	KRK		
MATERIAL	APP	DATE	
SH. SIZE	B	SCALE	X:X

REV. NO.	DATE	DESCRIPTION OF REVISION	BY	APP

