

ASV Shim

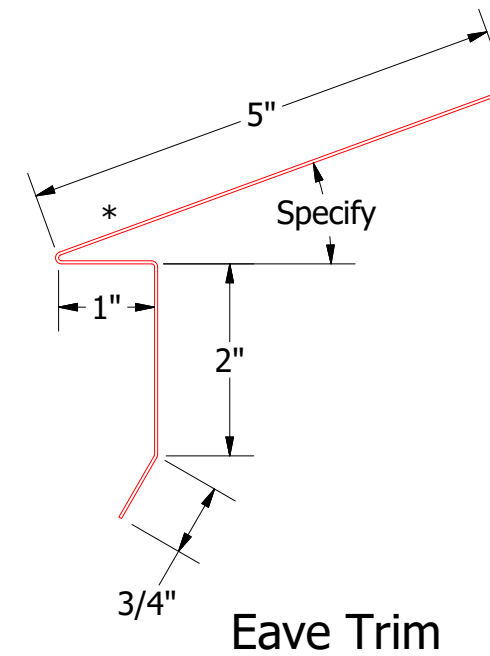

Eave Trim

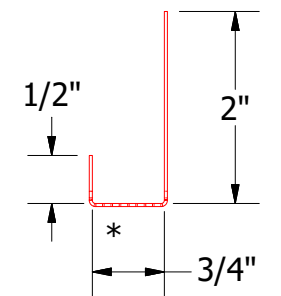

Perforated J Channel



ATAS INTERNATIONAL, INC
 Allentown PA
 610-395-8445
 Mesa AZ
 480-558-7210

Note: * denotes color side.

TITLE				Dutch Seam ASV Eave Detail			
01	4/29/2024	Updated Underlayment Description	KRK	DR	MBP	DATE	7/26/2017
REV. NO.	DATE	DESCRIPTION OF REVISION	BY	APP	SH. SIZE	SCALE	X:X

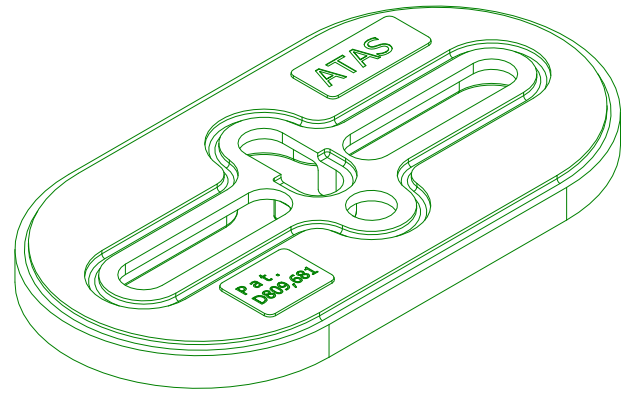

ASV Shim

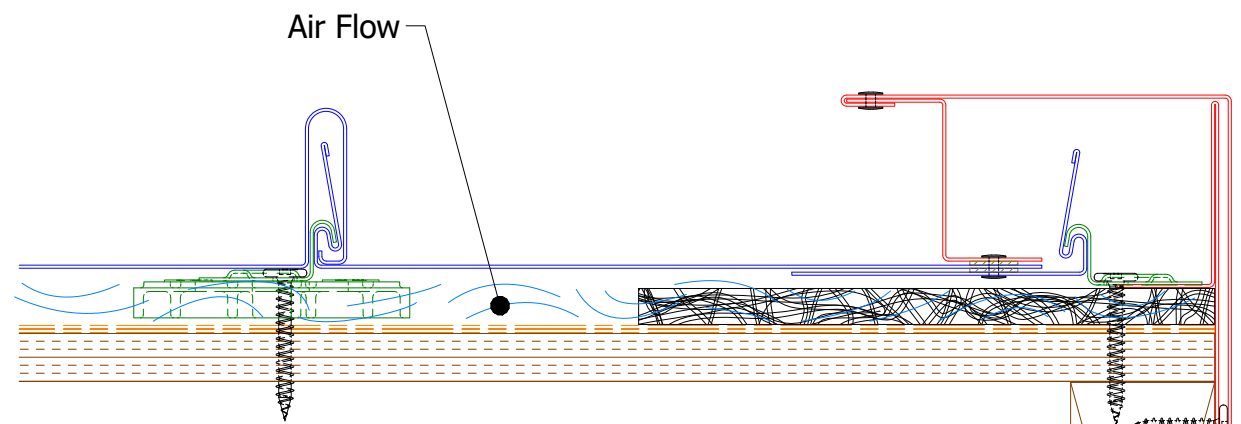
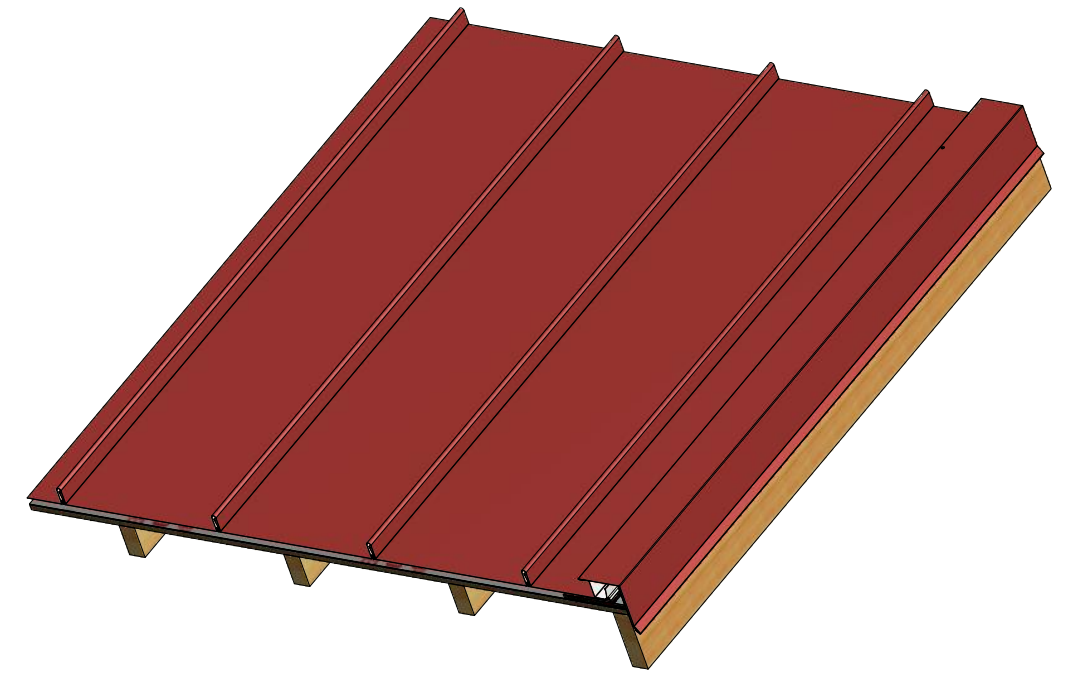
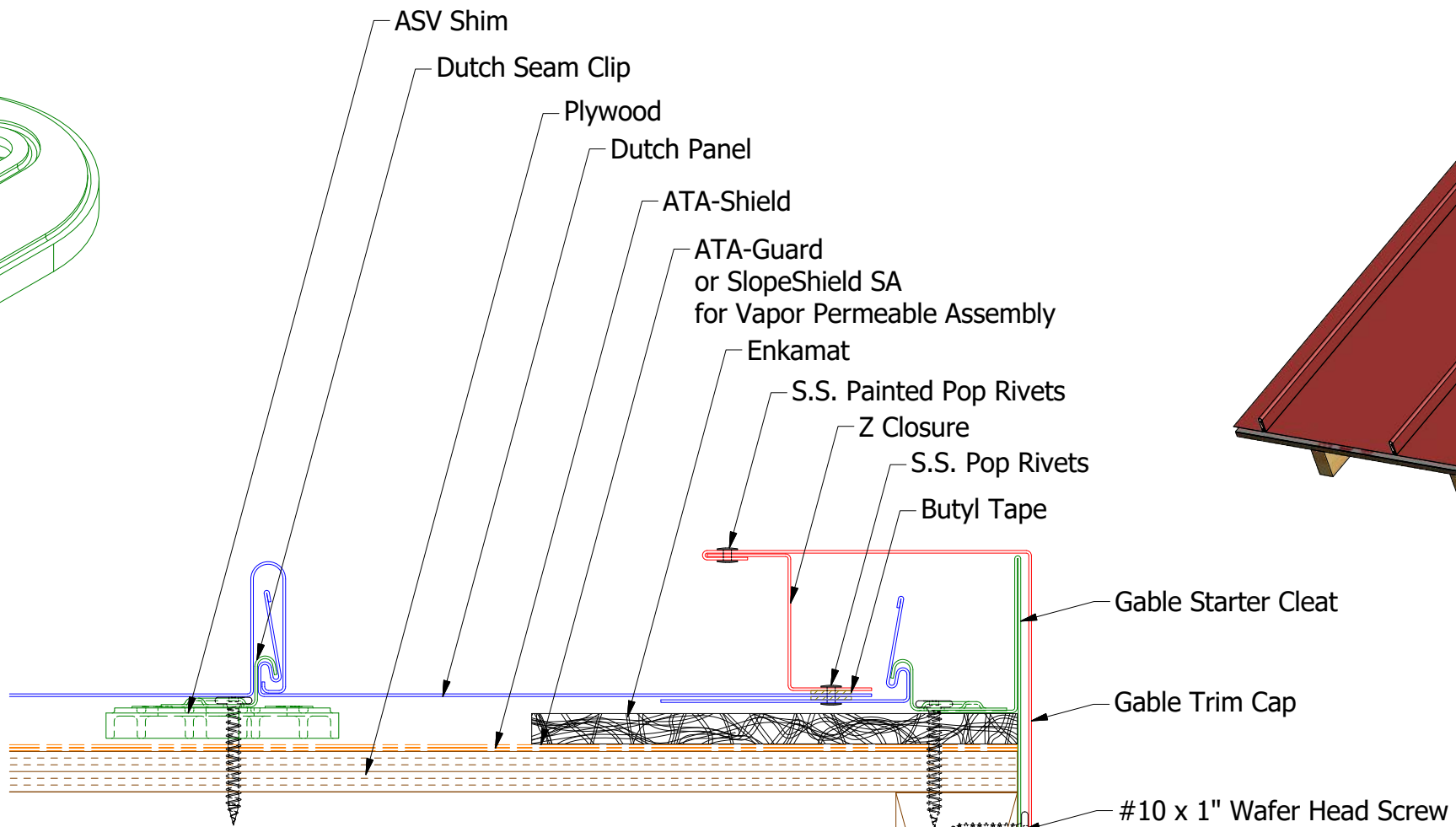

Air Flow

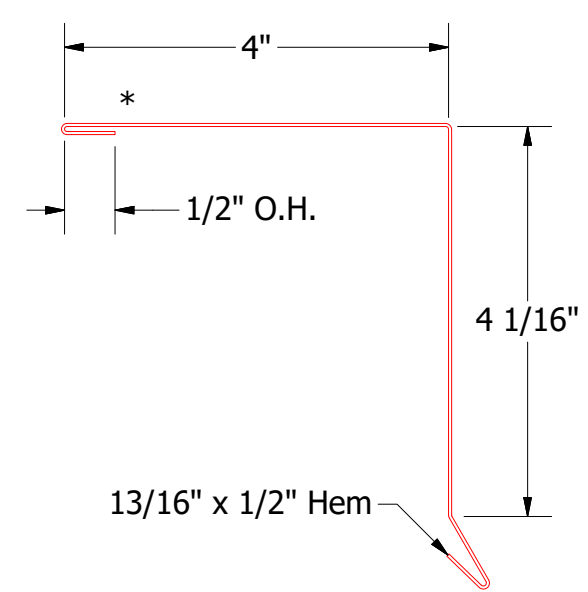

Gable Trim Cap

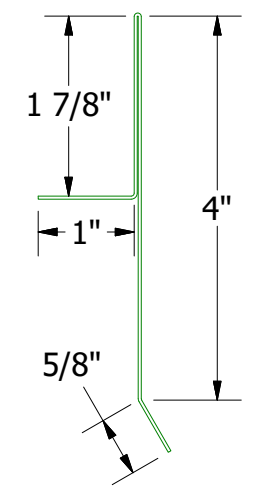

Gable Starter Cleat

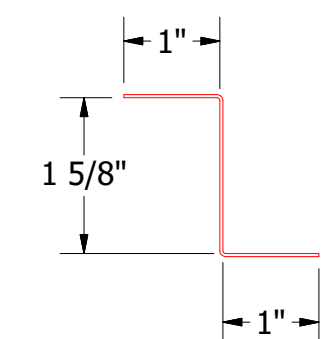

Z Closure

Note: * denotes color side.

ATAS ATAS INTERNATIONAL, INC
 Allentown PA
 610-395-8445
 Mesa AZ
 480-558-7210

TITLE				Dutch Seam ASV Gable Detail			
DWG. NO.		DR	MBP	DATE	7/26/2017	APP	
REV. NO.	DATE	DESCRIPTION OF REVISION	BY	APP		SH. SIZE	B
01	5/1/2024	Updated Trim Dimensions and Underlayment Description	KRK			SCALE	X:X

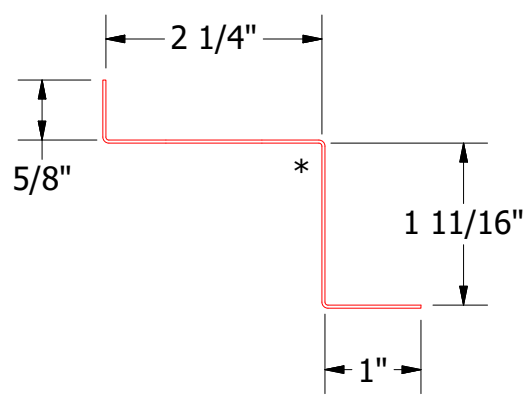

Non-Vented Z Closure

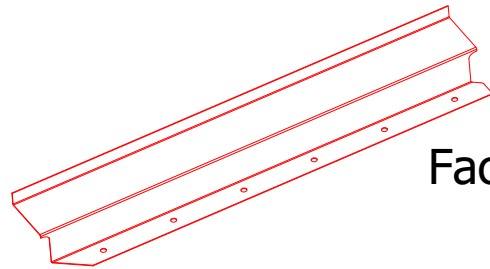

Factory Non-Vented Pre Notched Z Closure

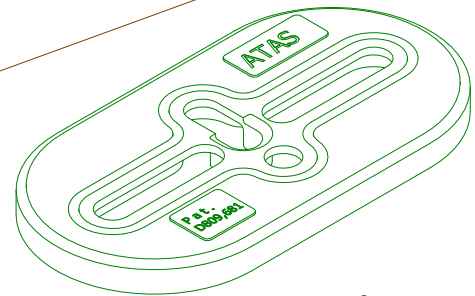
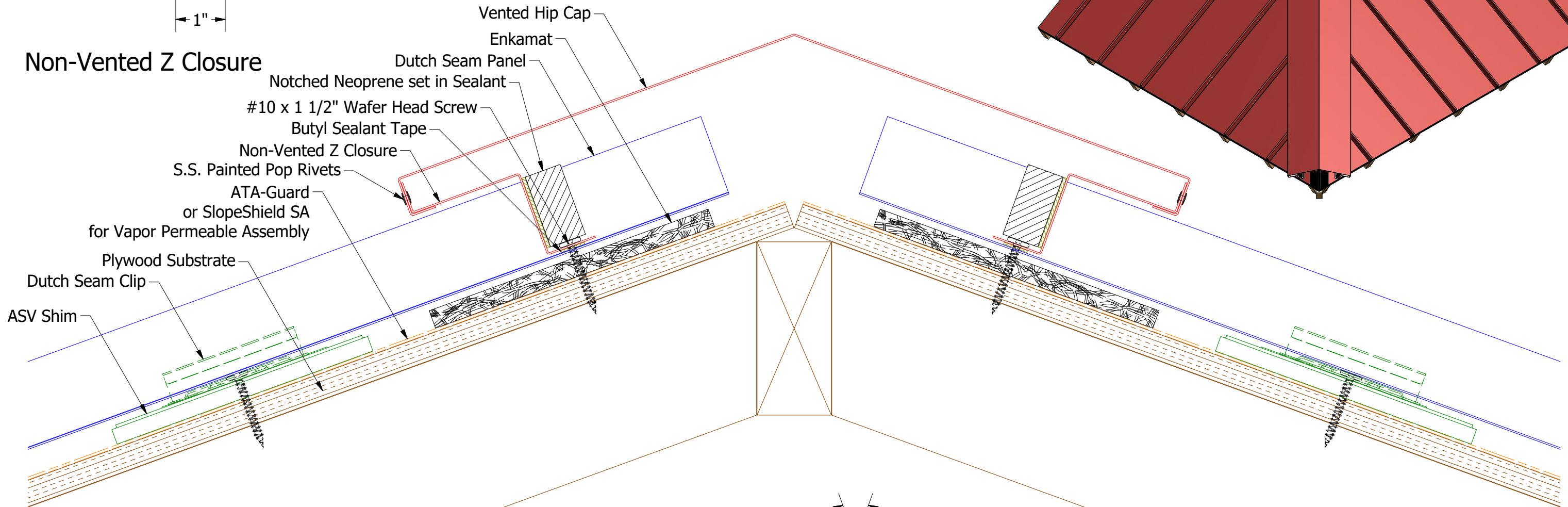
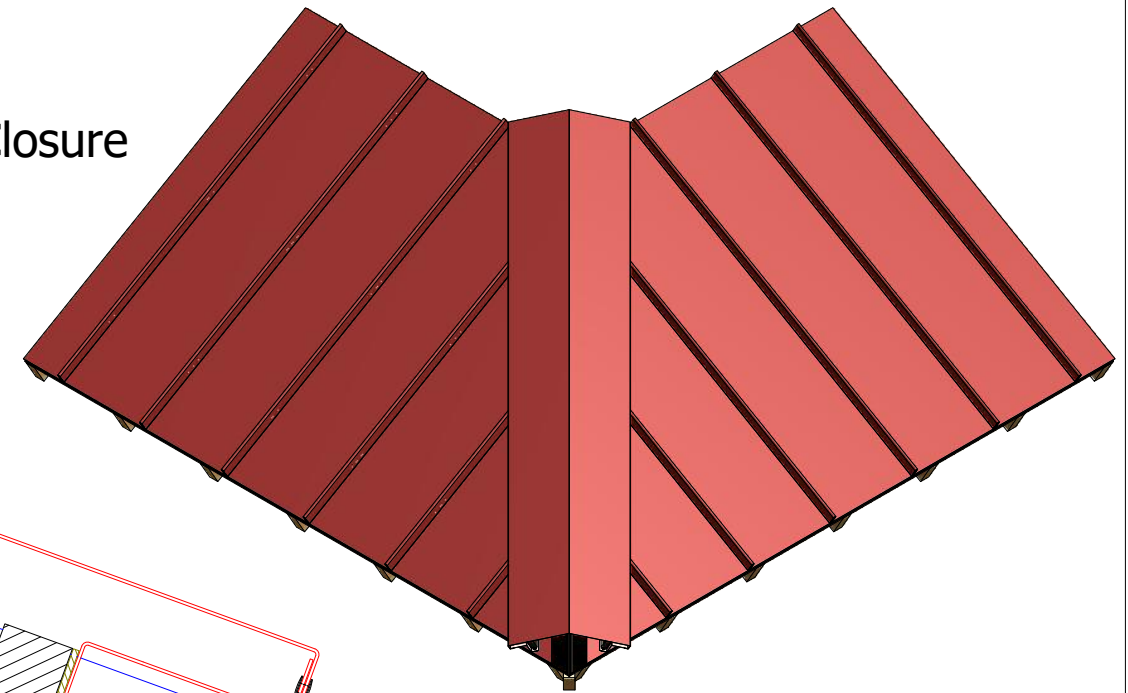

ASV Shim

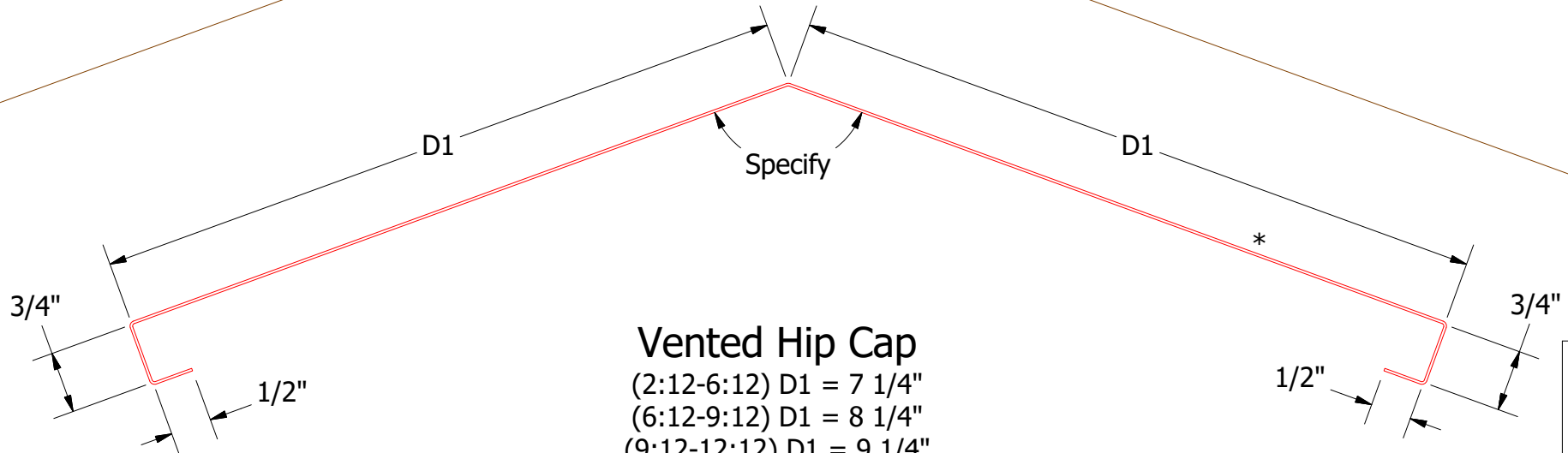

Vented Hip Cap
 (2:12-6:12) D1 = 7 1/4"
 (6:12-9:12) D1 = 8 1/4"
 (9:12-12:12) D1 = 9 1/4"

ATAS ATAS INTERNATIONAL, INC
 Allentown PA
 610-395-8445
 Mesa AZ
 480-558-7210

TITLE				Dutch Seam ASV Hip Detail		
02	5/23/2024	Updated Underlayment Description	KRK	DWG. NO.	DR MBP	DATE 7/26/2017
1	7/24/19	Updated Substrate and Assembly	AJZ KRK	APP		DATE
REV. NO.	DATE	DESCRIPTION OF REVISION	BY	APP	MATERIAL	SH. SIZE B SCALE X:X

Note: * denotes color side.
 Note: Neoprene Closures are not required if Factory Pre Notched Z Closures are utilized.

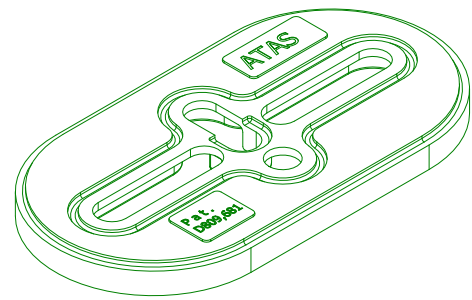

ASV Shim

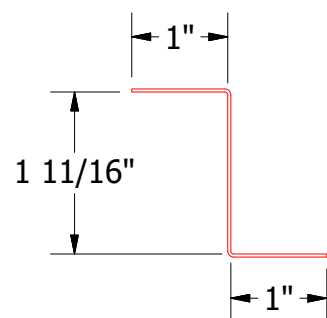
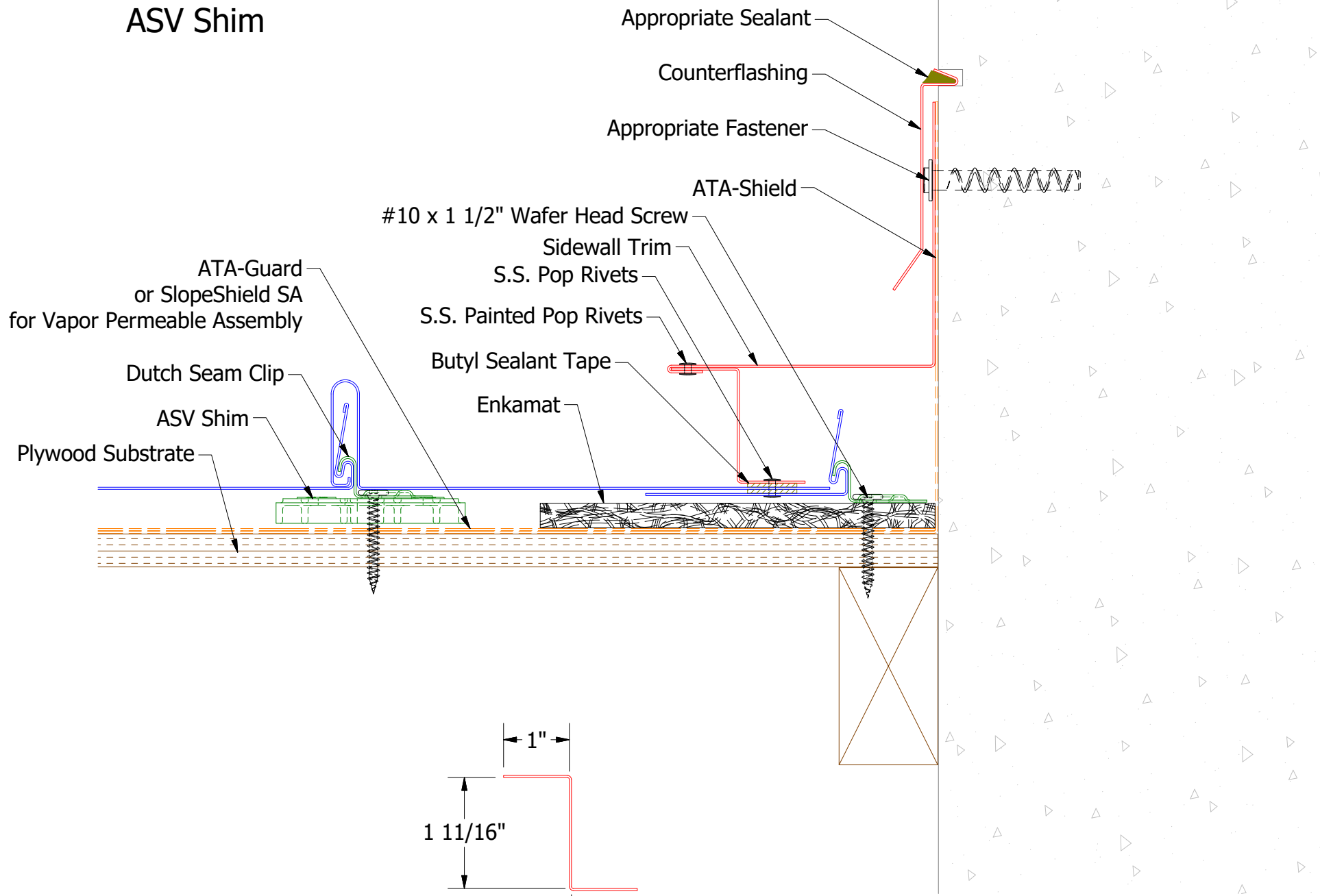

Z Closure

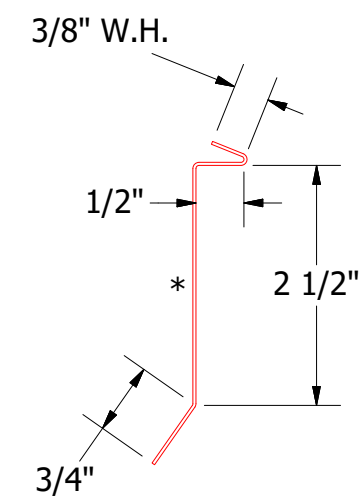
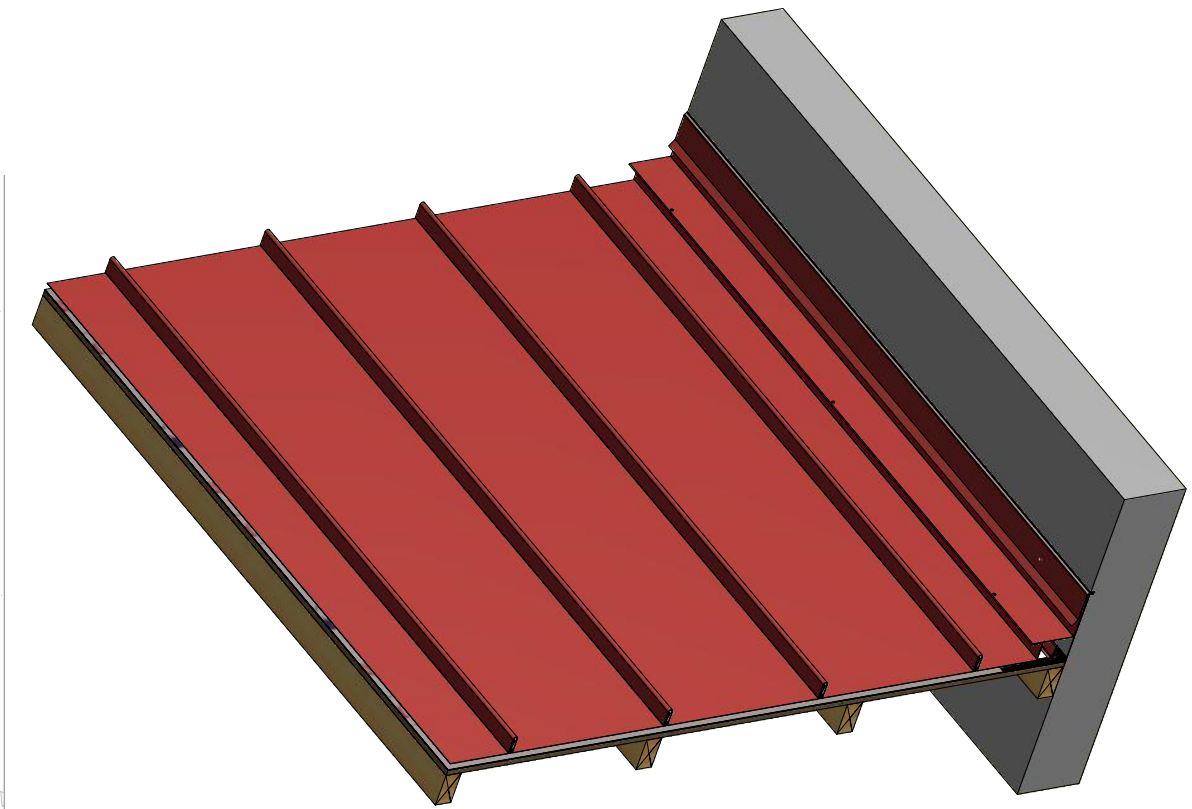

Counterflashing

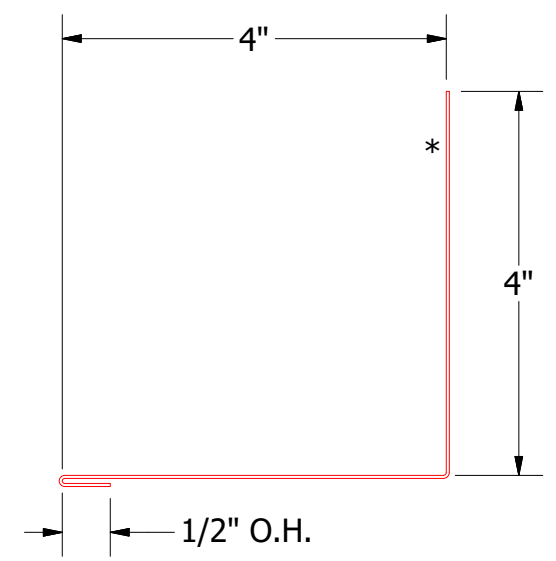

Sidewall Trim

ATAS
 ATAS INTERNATIONAL, INC
 Allentown PA
 610-395-8445
 Mesa AZ
 480-558-7210

TITLE **Dutch Seam ASV Sidewall Detail**

01	5/24/2024	Updated Underlayment Description	KRK	DR	MBP	DATE	7/26/2017
REV. NO.	DATE	DESCRIPTION OF REVISION	BY	APP	SH. SIZE	SCALE	X:X

Note: * denotes color side.
 Note: Neoprene Closures are not required if Factory Pre Notched Z Closures are utilized.

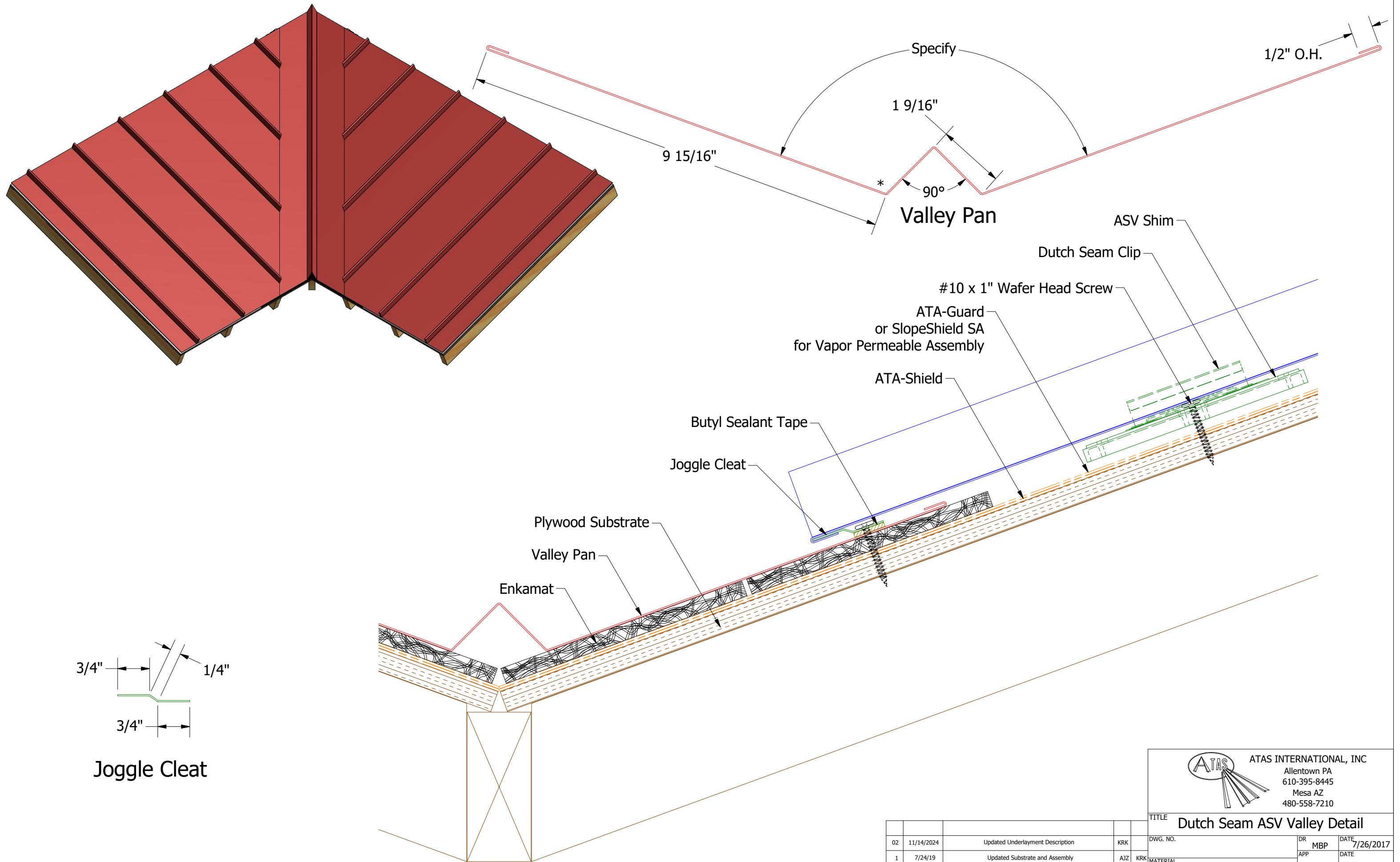

Note: * denotes color side.



ATAS INTERNATIONAL, INC
 Allentown PA
 610-395-8445
 Mesa AZ
 480-558-7210

REV. NO.				DATE		DESCRIPTION OF REVISION		BY		APP		TITLE	
02	11/14/2024	Updated Underlayment Description	KRK										Dutch Seam ASV Valley Detail
1	7/24/19	Updated Substrate and Assembly	AJZ	KRK									

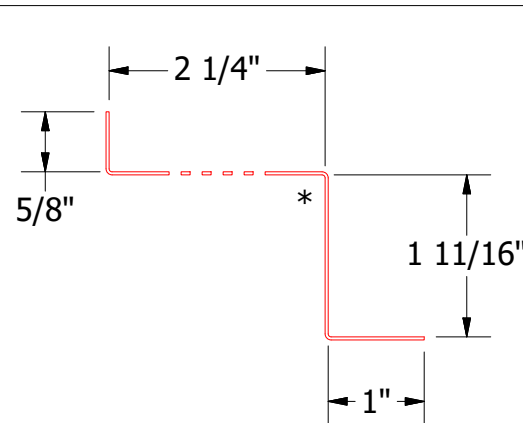
DWG. NO.	DR	DATE
	MBP	7/26/2017
MATERIAL	APP	DATE
SH. SIZE	B	SCALE
		X:X

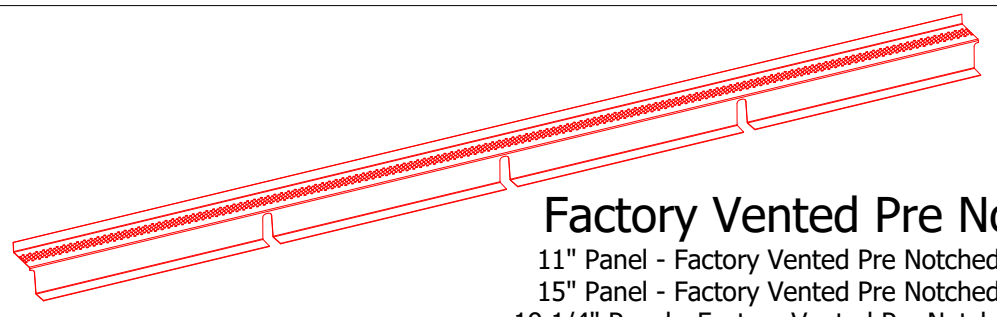

Vented Z Closure



Factory Vented Pre Notched Z Closure
 11" Panel - Factory Vented Pre Notched Z Closure will cover 5 Panels.
 15" Panel - Factory Vented Pre Notched Z Closure will cover 4 Panels.
 19 1/4" Panel - Factory Vented Pre Notched Z Closure will cover 3 Panels.

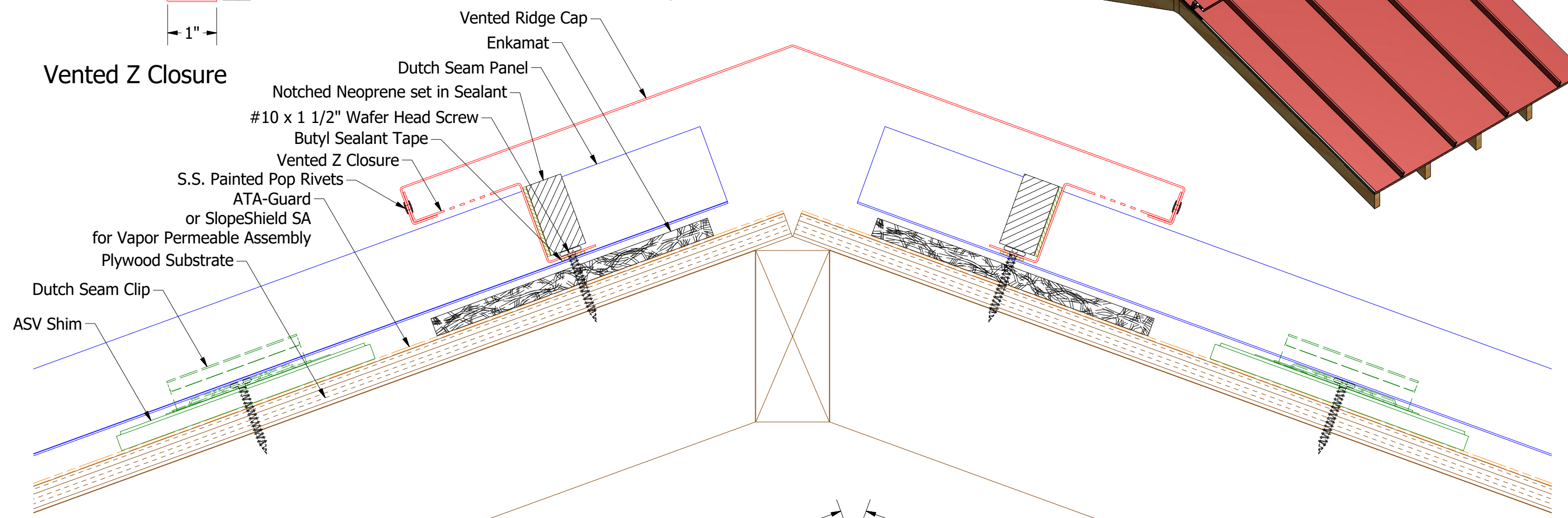
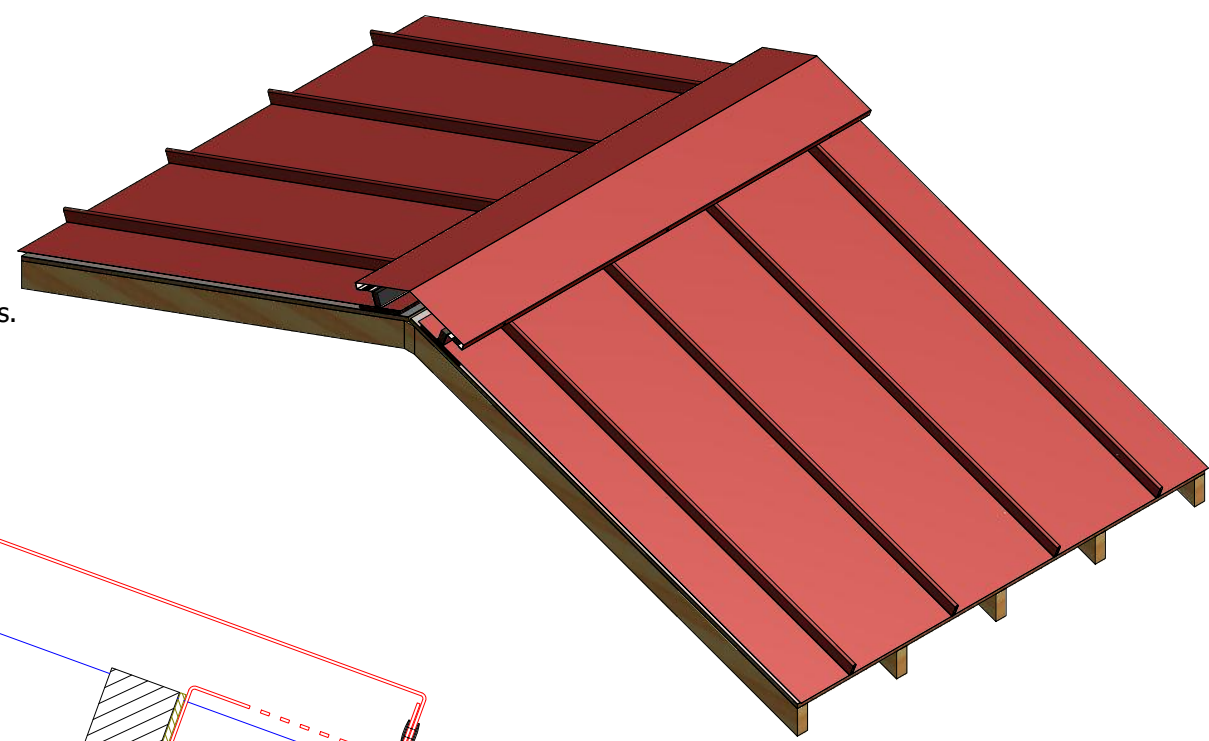

- Notched Neoprene set in Sealant
- #10 x 1 1/2" Wafer Head Screw
- Butyl Sealant Tape
- Vented Z Closure
- S.S. Painted Pop Rivets
- ATA-Guard or SlopeShield SA for Vapor Permeable Assembly
- Plywood Substrate

- Dutch Seam Clip
- ASV Shim

- Vented Ridge Cap
- Enkamat
- Dutch Seam Panel

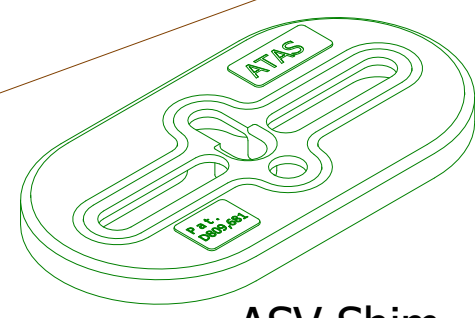

ASV Shim

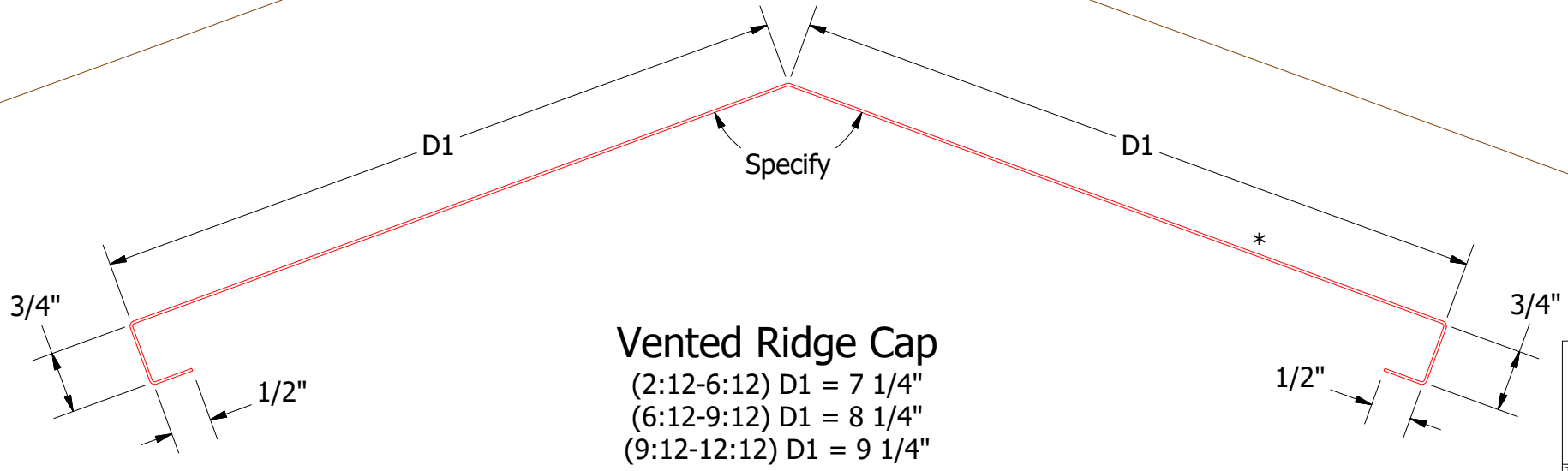

Vented Ridge Cap
 (2:12-6:12) D1 = 7 1/4"
 (6:12-9:12) D1 = 8 1/4"
 (9:12-12:12) D1 = 9 1/4"

ATAS ATAS INTERNATIONAL, INC
 Allentown PA
 610-395-8445
 Mesa AZ
 480-558-7210

TITLE		Dutch ASV Ridge Detail	
REV. NO.	DATE	DESCRIPTION OF REVISION	BY
02	5/16/2024	Updated Underlayment Description	KRK
1	7/24/19	Updated Substrate and Assembly	AJZ KRK
DWG. NO.		DR MBP DATE 7/26/2017	
MATERIAL		APP DATE	
SH. SIZE		SCALE X:X	

Note: * denotes color side.
 Note: Neoprene Closures are not required if Factory Pre Notched Z Closures are utilized.

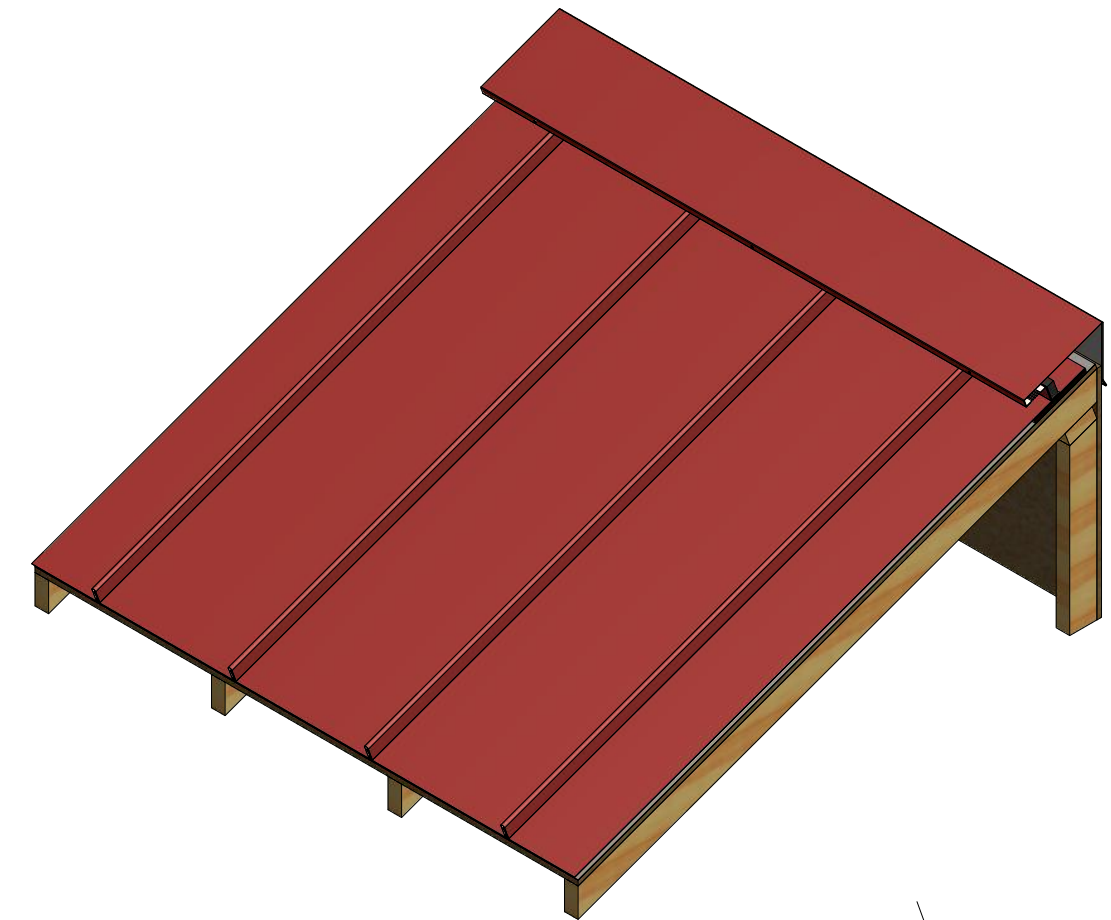
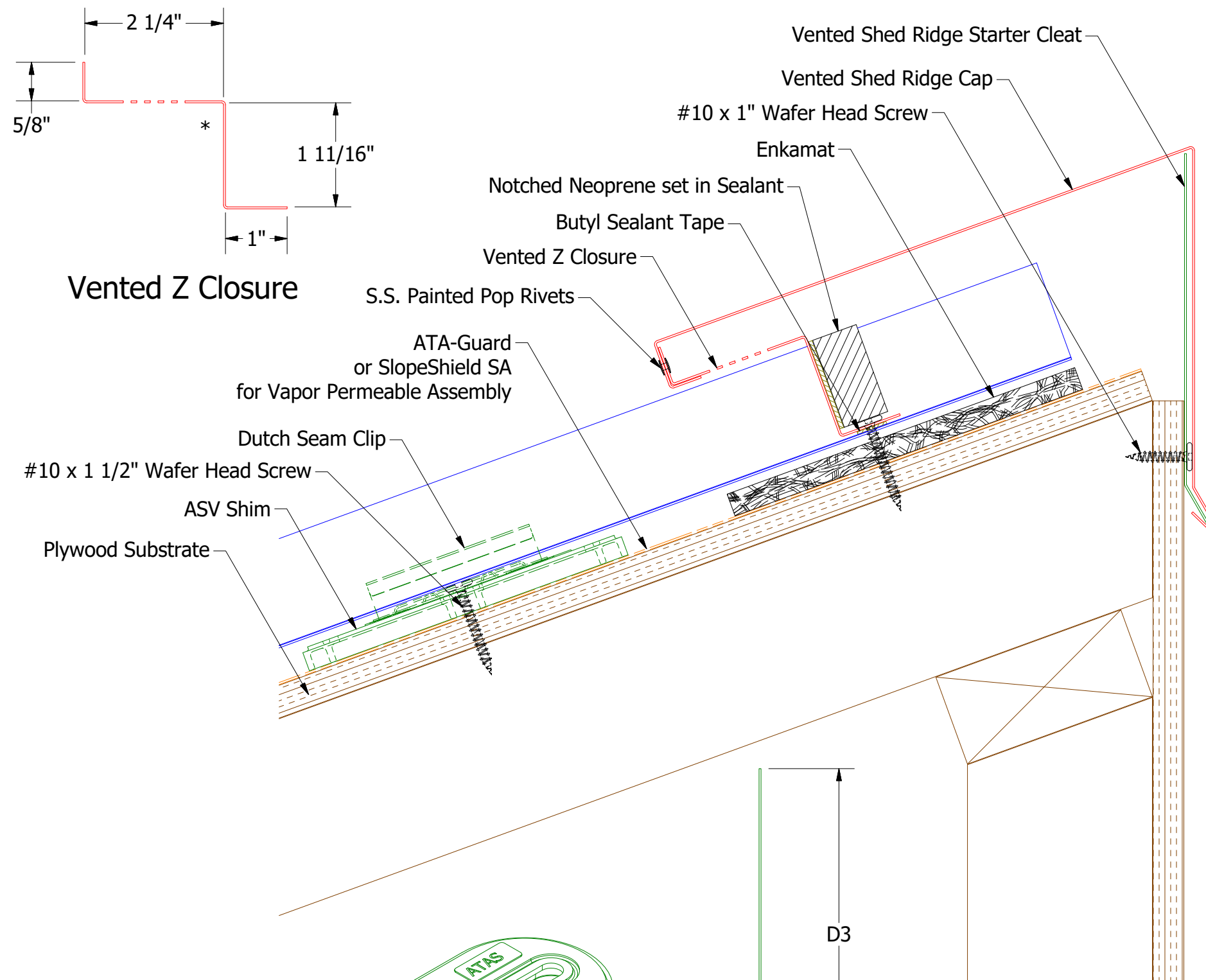

Vented Z Closure

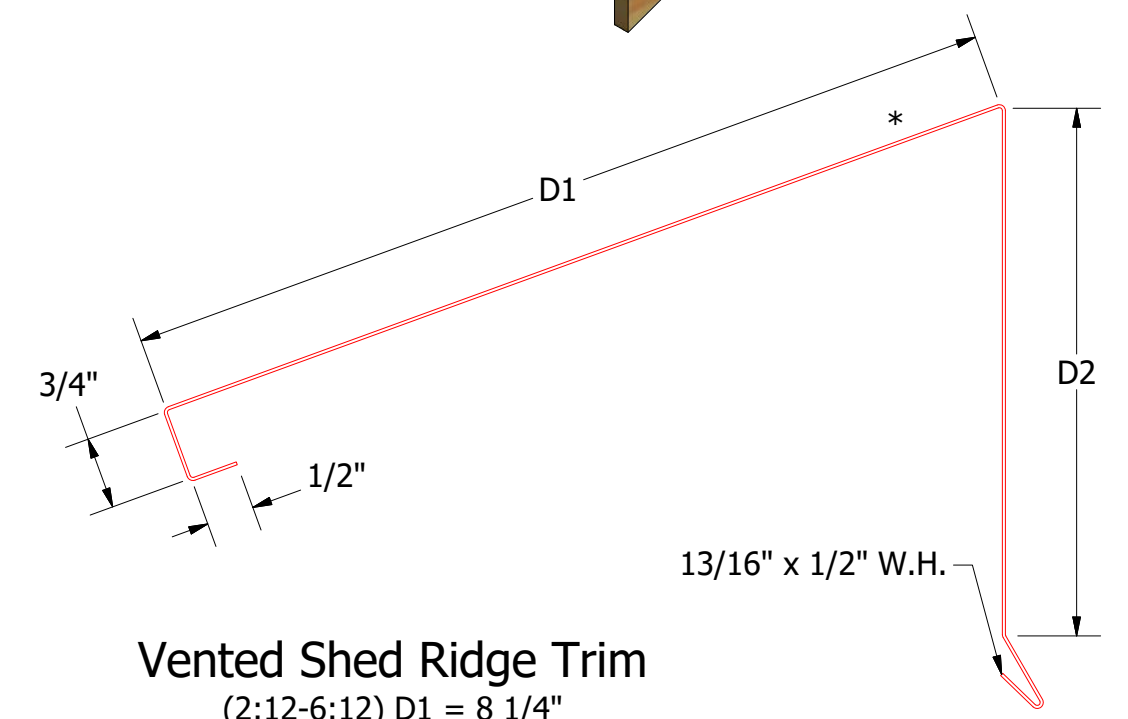

Vented Shed Ridge Trim

- (2:12-6:12) D1 = 8 1/4"
- D2 = 5 1/2"
- (6:12-9:12) D1 = 9 1/4"
- D2 = 5 3/4"
- (9:12-12:12) D1 = 10 1/4"
- D2 = 6"

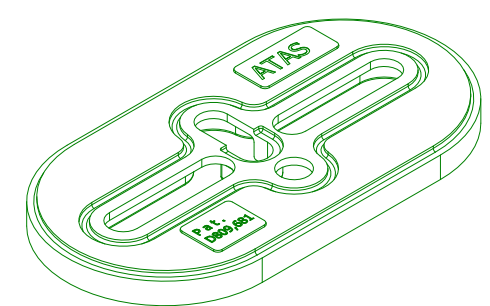

ASV Shim

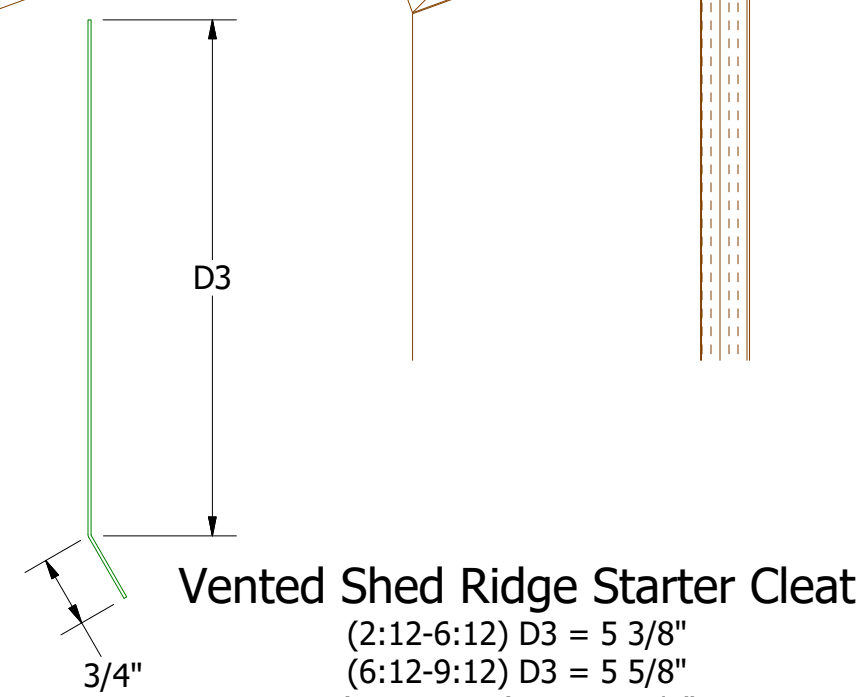

Vented Shed Ridge Starter Cleat

- (2:12-6:12) D3 = 5 3/8"
- (6:12-9:12) D3 = 5 5/8"
- (9:12-12:12) D3 = 5 7/8"

ATAS ATAS INTERNATIONAL, INC
 Allentown PA
 610-395-8445
 Mesa AZ
 480-558-7210

Dutch Seam ASV Shed Ridge Detail

Note: * denotes color side.
 Note: Neoprene Closures are not required if Factory Pre Notched Z Closures are utilized.

REV. NO.	DATE	DESCRIPTION OF REVISION	BY	APP	DWG. NO.	DR	DATE
02	5/24/2024	Updated Underlayment Description	KRK			MBP	7/26/2017
1	7/24/19	Updated Substrate and Assembly	AJZ	KRK			
					MATERIAL		
						SH. SIZE	B
						SCALE	X:X