

- (670TE) Starter Cleat 5.375"
* Pairs with 640.1U
- (670UE) Starter Cleat 6.375"
* Pairs with 640.1V
- (670VE) Starter Cleat 7.375"
* Pairs with 640.1W
- (640.1U) Shed Ridge Cap 6.000" x 5.500" (1:12 - 4:12)
*(640.2TO) Shed Ridge Splice 5.938" x 5.563"
- (640.1V) Shed Ridge Cap 7.000" x 6.500" (5:12 - 8:12)
*(640.2UO) Shed Ridge Splice 6.938" x 6.563"
- (640.1W) Shed Ridge Cap 8.000" x 6.500" (9:12 - 12:12)
*(640.2VO) Shed Ridge Splice 7.938" x 6.563"

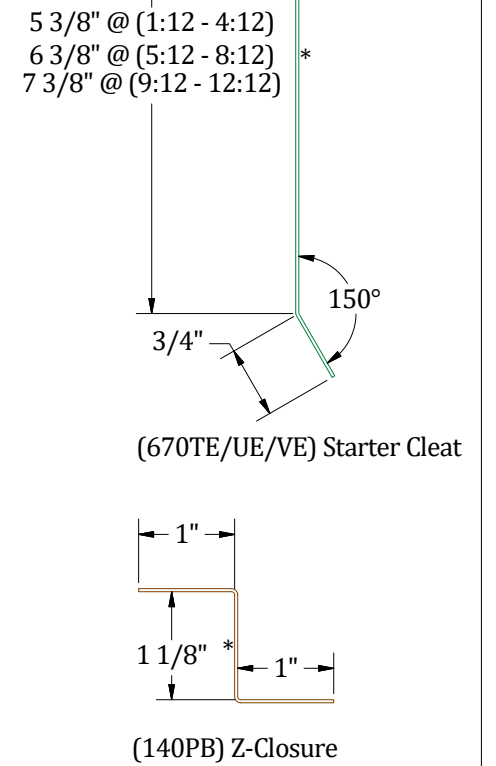
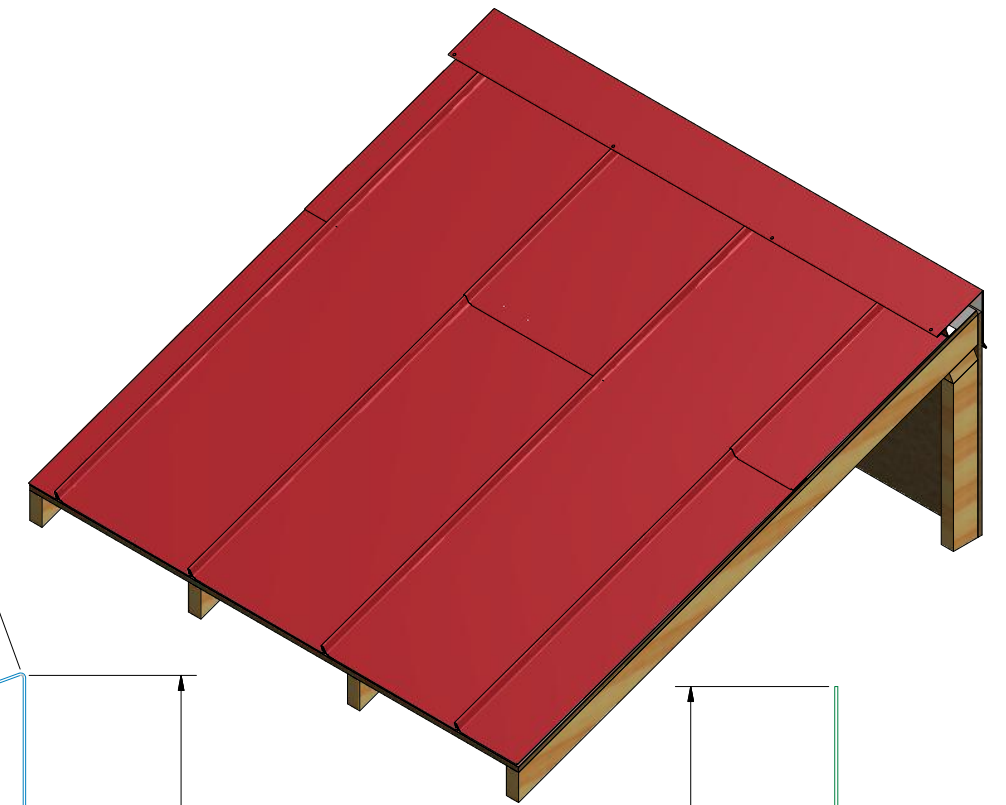
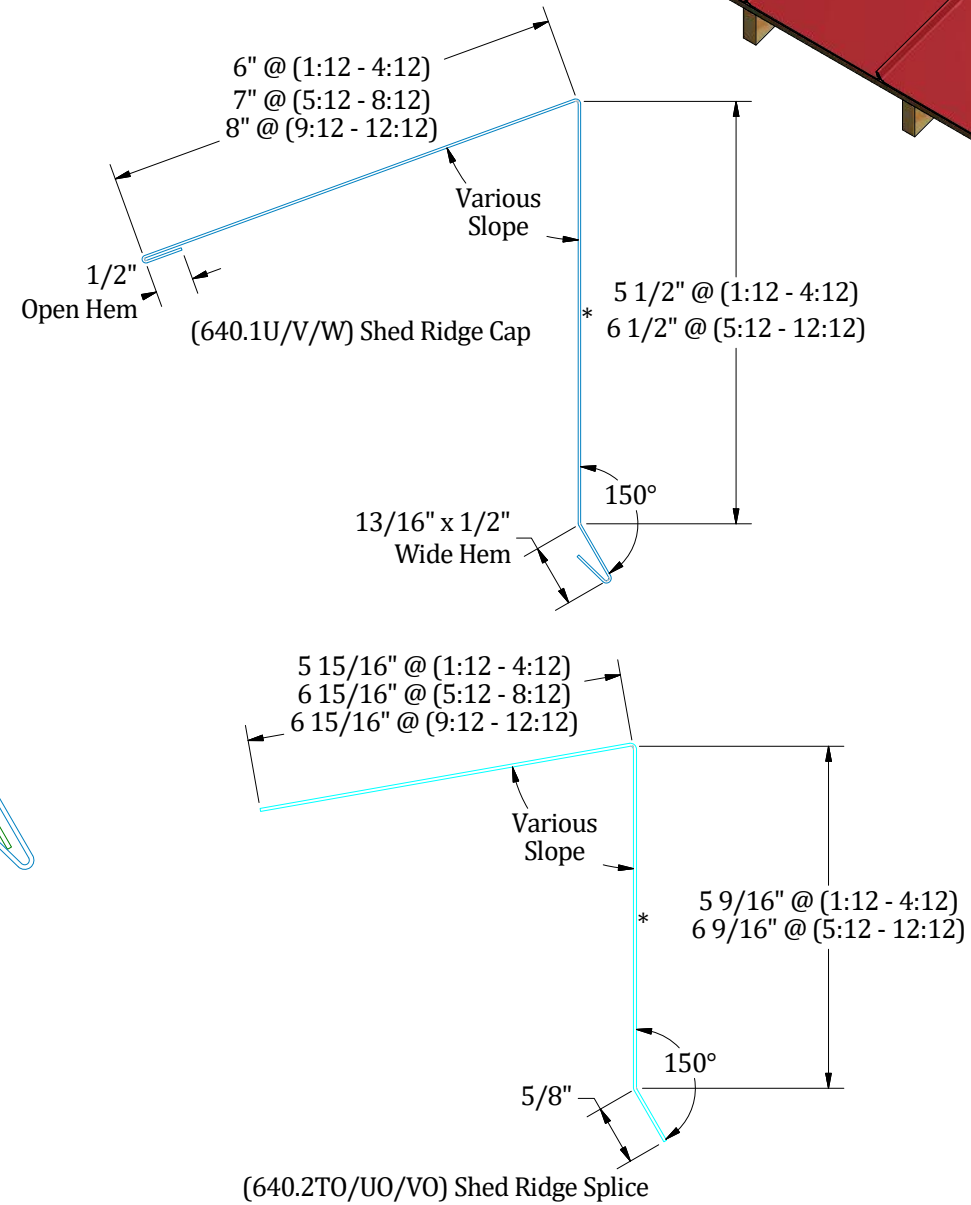
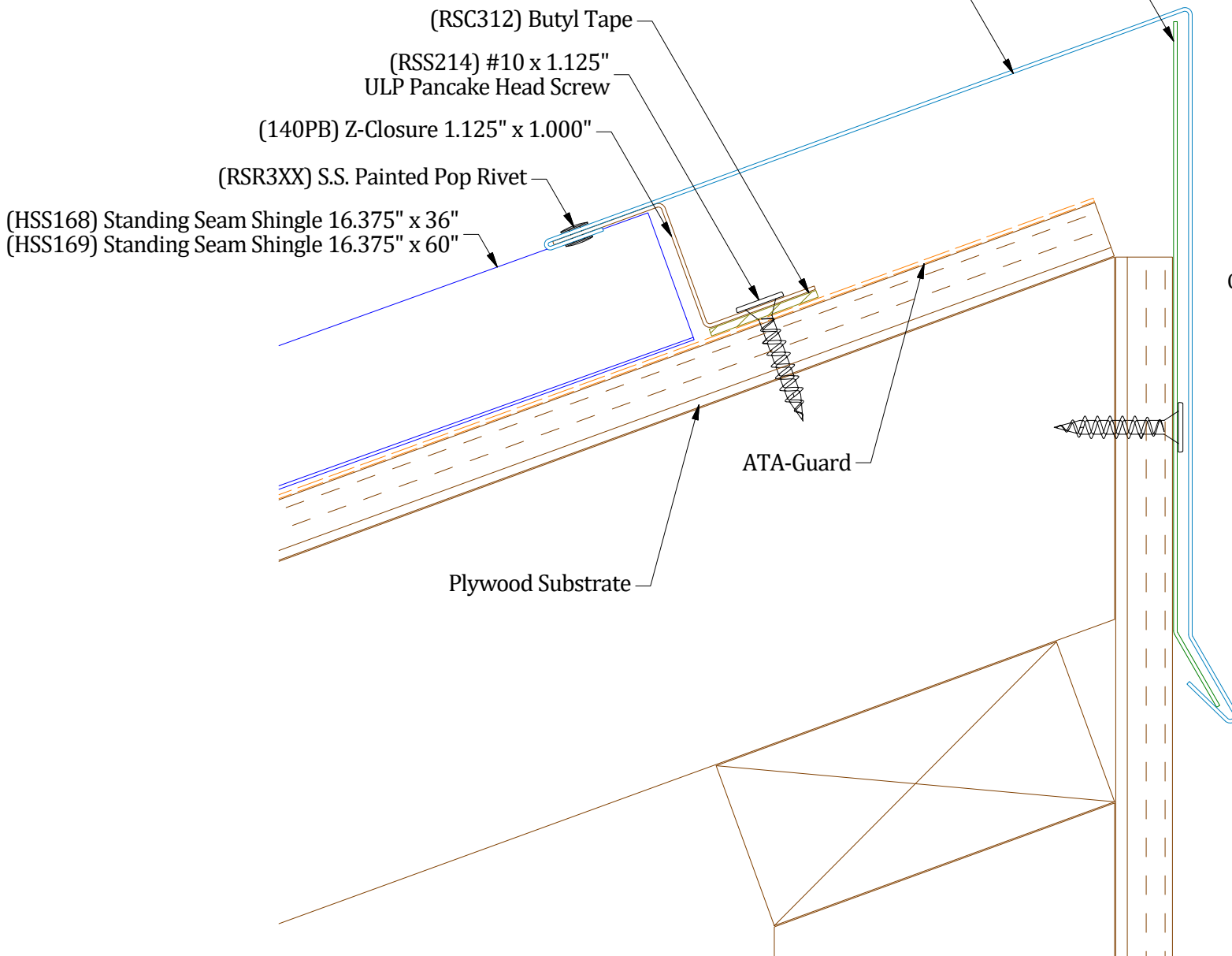

ATAS ATAS INTERNATIONAL, INC
Allentown PA
610-395-8445
Mesa AZ
480-558-7210

NOTES:
1) * Denotes color side.

REV. NO.	DATE	DESCRIPTION OF REVISION	BY	APP	MATERIAL	SH. SIZE	SCALE
03	11JUN25	Updated Panels to (HSS168) & (HSS169) per new interlock design.	M.L.P	J.B	HSS640SVS-A1	B	X:X
02	18NOV20	Changed Fastener to ULP Pancake Head Fastener	K.R.K	J.B			
01	11JUN19	Updated Substrate and Clip Information	A.J.Z	K.R.K			

TITLE Standing Seam Alt. Shed Ridge Detail

DWG. NO. HSS640SVS-A1
DR. K.R.K. DATE 26NOV14
APP. J.B. DATE 26NOV14
SH. SIZE B SCALE X:X