

Note: Start/End Vented Closure Angle runs with at least 2'-0" of Non-Vented Closure Angles.

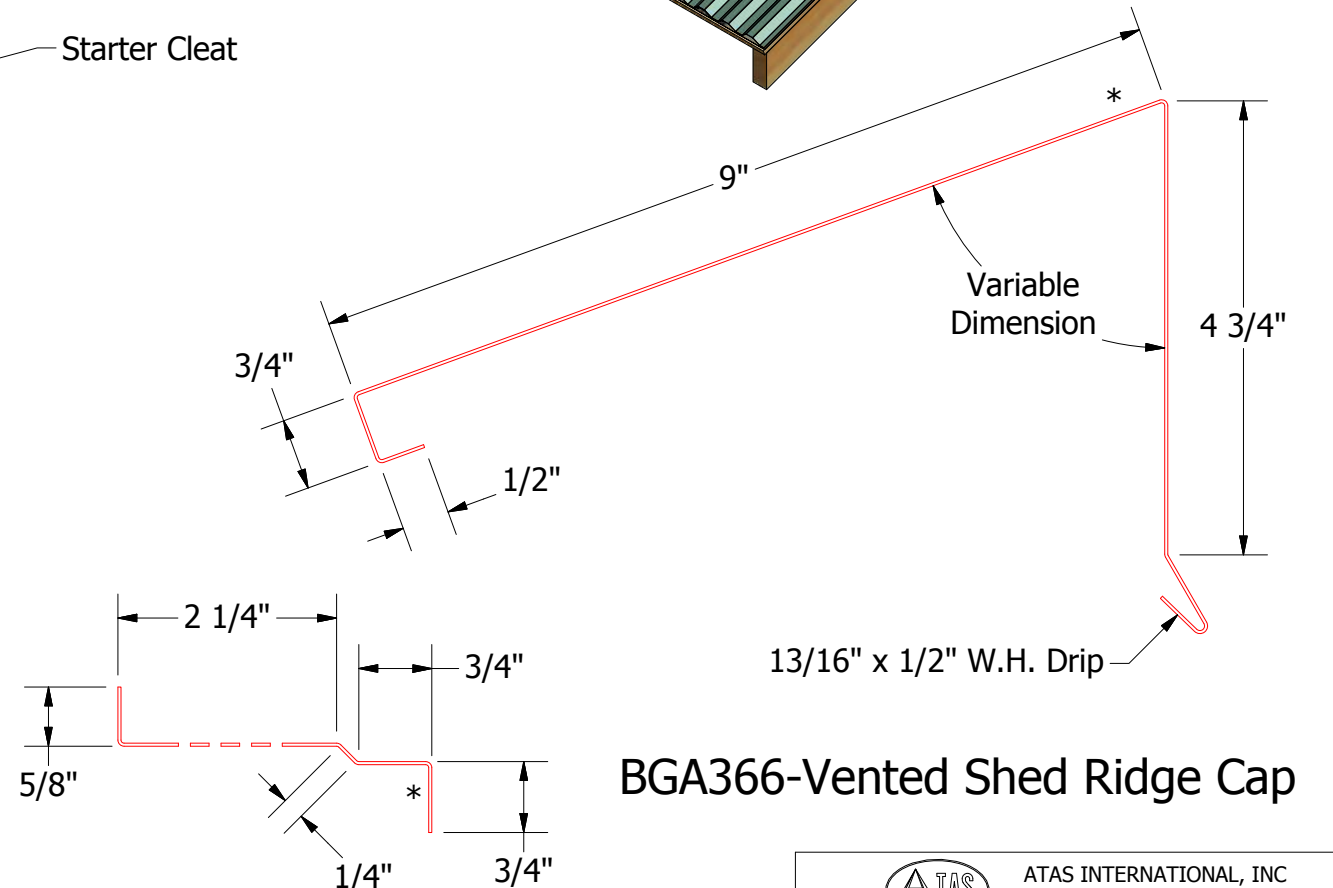
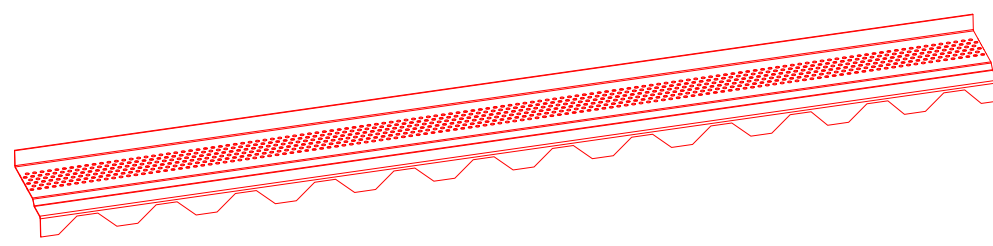
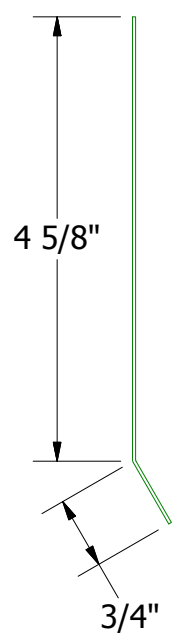
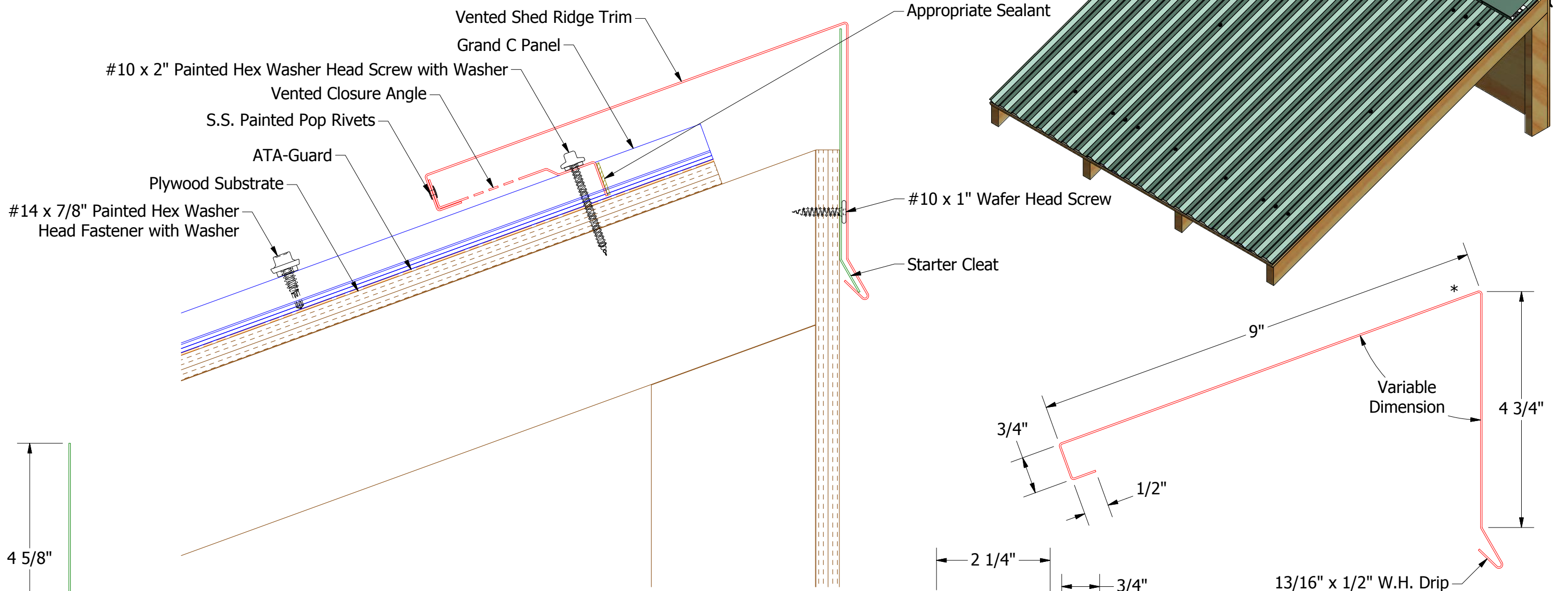

BGA369-Starter Cleat

BGA911-Vented Closure Angle

BGA366-Vented Shed Ridge Cap

ATAS ATAS INTERNATIONAL, INC
 Allentown PA
 610-395-8445
 Mesa AZ
 480-558-7210

TITLE: Grand C Vented Shed Ridge Detail			
DWG. NO.	DR	DATE	
01	KRK	1/13/2017	
REV. NO.	APP	DATE	
01	APP		
DATE	SH. SIZE	SCALE	
3/13/2019	B	X:X	
DESCRIPTION OF REVISION	BY	APP	
Updated Vented Closure Angle from Louvers to Perforations	KRK	APP	