



Transpired Solar Collector System Installation Guide

(Updated: 2026-05-22)

Table of Contents

Transpired Solar Collector System Installation Guide	1
GENERAL	2
Purpose:	2
Design:	2
Collector specifications	3
INSTALLATION GUIDELINES	4
Mounting Framing to Existing Walls:	5
Perimeter and Vertical framing	4
Horizontal framing	6
Positioning of InSpire Wall Panel.	9
<i>Panel Lap Detail</i>	10
Panel Coverage Detail.....	10
Flashings and trims	11
Fixing the product label on the collector.....	15
EXTRA PRECAUTIONS FOR INSPIRE HP PANELS.....	15
Receiving and storage	15
Panels on the ground during installation	16
Removal of protective film upon fastening on the wall	17
<i>Method 1: removing film on the ground.</i>	17
<i>Method 2: removing film on the vertical wall</i>	18

GENERAL

Purpose:

Transpired Solar Collector Summary

The InSpire wall system is designed to provide solar heated air from outside air source before it enters the building to provide fresh air changes and natural humidification, as well as opportunities to reduce energy consumption.

The InSpire transpired solar collector can be used as a direct-to-space heating system or to preheat replenishment air for institutional and commercial facilities. The direct-to-space heating system can be used for large open spaces such as hangers, light manufacturing, maintenance garages and industrial buildings as a sole source of heat. Both systems may require summer bypass louver vents that are critical to expel heat during summer when the heat is not needed in the structure. These bypass vents are critical to proper system operation and should be installed according to the shop drawings and details included at time of construction.

Design:

The InSpire wall is offset several inches or more from the outer wall of the building. InSpire features proprietary engineered perforations which allow outside air to be transpired (drawn through the wall panel) into the wall cavity via ventilation fans. InSpire wall panels are coated with a fluoropolymer (PVDF) coating system in colors which allow absorption of the sun's energy to pre-heat surface and cavity air. The solar generated pre-heated air transpires into the wall cavity and is drawn into the building's interior through conventional ductwork.

ATAS engineering services will facilitate proper design and specifications for the transpired wall system on each individual project including but not limited to framing, flat stock, trim, transpired panels, fasteners, and in some cases the ventilation, HVAC controls and energy savings monitoring systems, however ATAS is a sheet metal manufacturing and sales facility and does not claim to be an HVAC professional. The building and or HVAC engineer on each individual project is ultimately responsible for the operation and integration of the InSpire wall system into the buildings design.

Because the InSpire wall system is designed specifically to draw outside air through the perforations in the face of the wall it is essential to build this wall as airtight at all other areas as possible. This is not typical of a standard sheet metal wall and requires greater attention to detail specifically the sealing processes which will be both shown and explained in this Installation Guide. The efficiency and therefore the monetary payback of this system is greatly dependent on this wall being constructed properly.

Collector specifications

The InSpire line of products and colors can be divided into two categories:

- 1) The InSpire panel with traditional PVDF coating
- 2) The InSpire HP with very low emissivity and high temperature rise

Model	InSpire	InSpire HP
Certification number	10001914	10002109
Certification standard	SRCC OG-100	SRCC OG-100
Certification holder	ATAS International inc.	ATAS International inc.
Manufactured in:	USA	USA
Serial no.	ATAS drawing no.	ATAS drawing no.
collector type	transpired	transpired
dimensions	___ ft W x ___ ft H ___ m W x ___ m H	___ ft W x ___ ft H ___ m W x ___ m H
gross area	___ sq.ft. ___ m ²	___ sq.ft. ___ m ²
max. operating pressure	1" w.g. H ₂ O; 250 Pa negative	1" w.g. H ₂ O; 250 Pa negative
std. stagnation temperature	approx 232°F / 100°C (not measured)	247 °F; 119 °C
empty weight (per collector surface)	2 lbs per sq.ft.; 9.8 kg/m ²	2 lbs per sq.ft.; 9.8 kg/m ²
fluid volume (per collector surface)	0.5 cubic ft per sq.ft.; 0.127 m ³ per m ²	0.5 cubic ft per sq.ft.; 0.127 m ³ per m ²
fluid type	air	air

Note: all items in black are constant values; all items in red are project-specific

INSTALLATION GUIDELINES

Example 1.)
Installation over masonry.

Example 2.)
Installation over metal.

Example 3.)
Installation over Insulation
board.

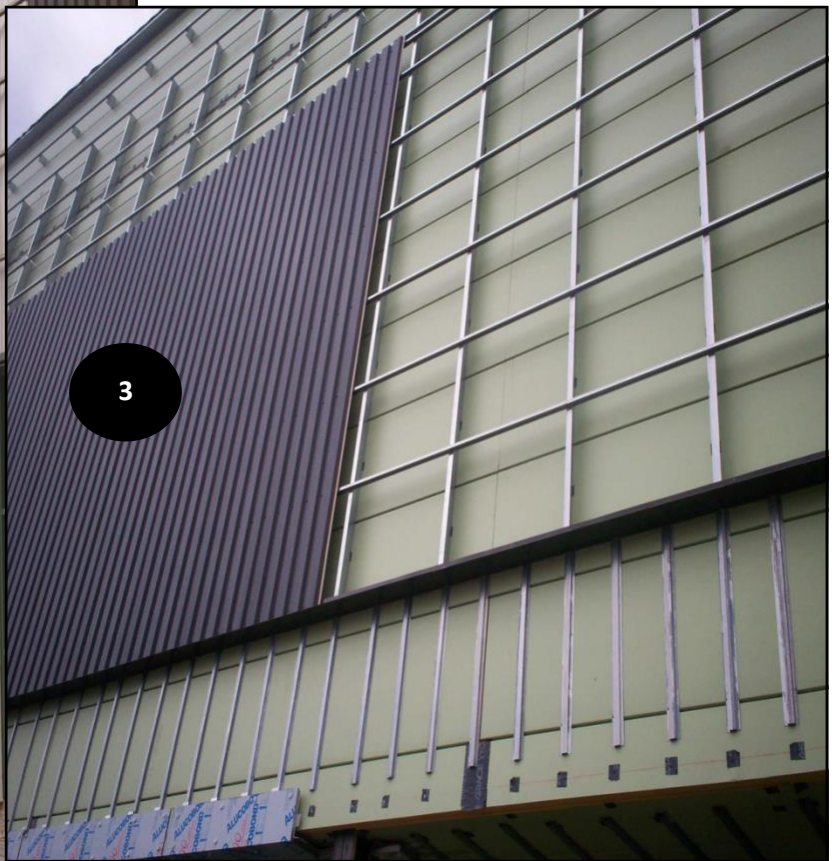
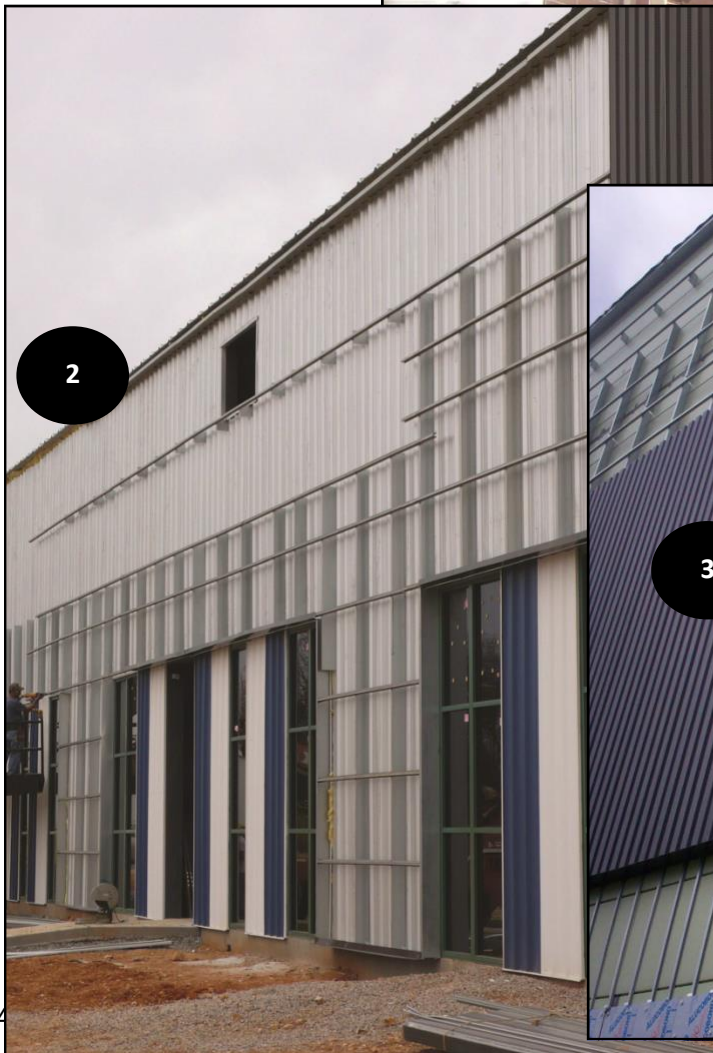

Mounting Framing to Existing Walls:

There is no typical installation for the InSpire transpired collector system. This system can be installed over any wall system with the proper planning, designing and installation procedures. Mounting to the existing wall system will not be fully addressed in this installation guide. It must be noted however that this system is not waterproof. The wall behind this system must have an approved waterproof underlayment or membrane installed before construction of this wall begins. The water infiltration through this wall when properly installed will only be through the perforations in the face and this has been addressed by the specially designed bottom trim which has a gutter style groove and very small holes to weep the water that passes through the wall away. The procedure that is used to mount this system to the existing structure must be designed to make the framing members stable and sturdy enough to mount the InSpire sheeting without jeopardizing the integrity of the wall system and eliminate the possibility of damage to the existing structure.

This vent location is also where the summer bypass louver would be located on the outside of the wall

Vertical "Z" framing

Horizontal "hat" framing

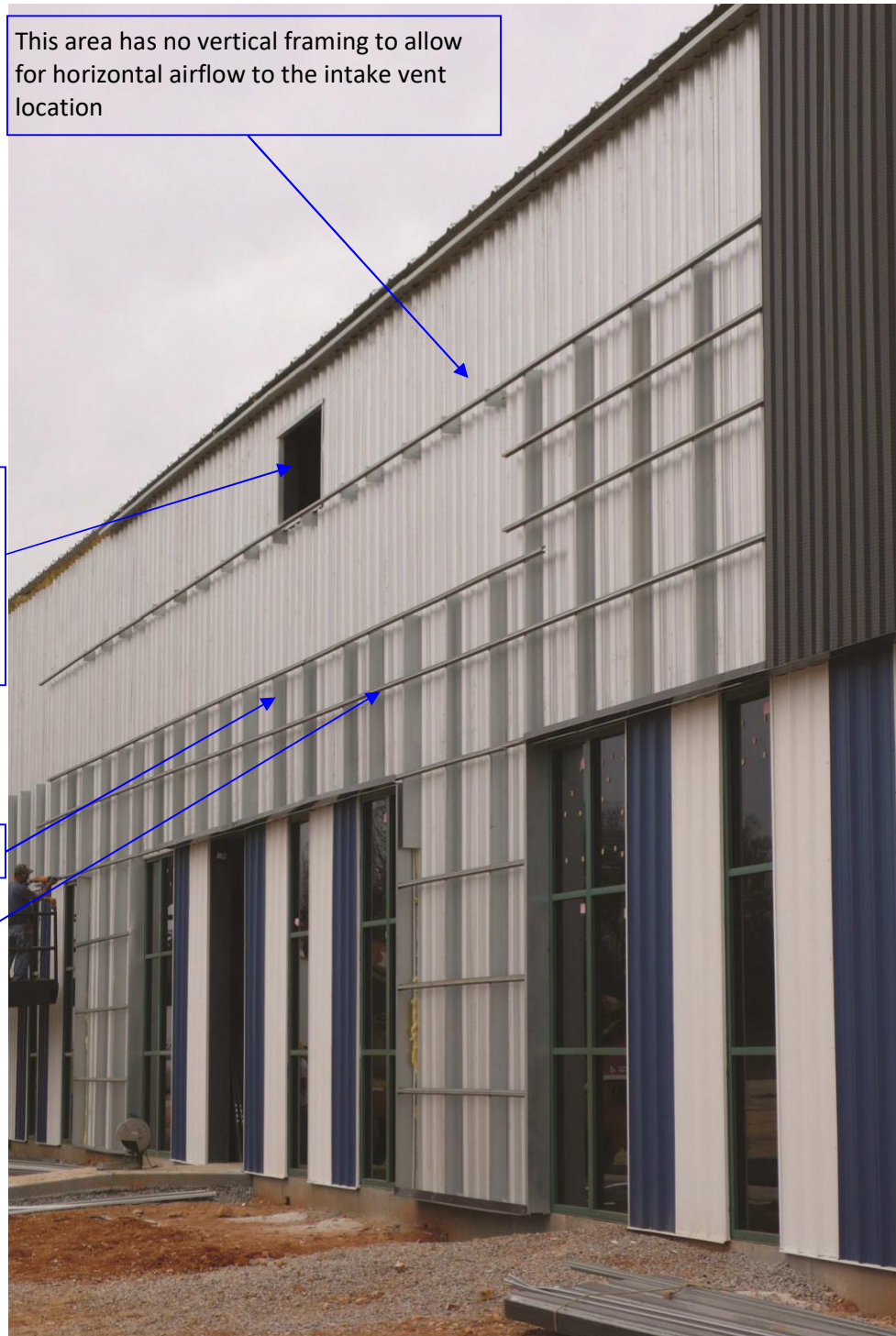

Perimeter and Vertical framing

Installation of InSpire Wall framing starts with the vented bottom flashing. This is a ribbed and perforated panel so that any water that penetrates the wall cavity can drain out. These small drain holes are the only area that air can penetrate this wall system other than the specifically designed perforations in the face of the wall panel. The next pieces to be installed are the 18ga. C channel framing to be se-cured around the top and side perimeter of the area that the InSpire wall system is to be installed.

Then the vertical zee sections are placed vertically in the middle area and secured to the substrate with an approved fastening system. There is no uniform procedure of fastening these framing members to the wall surface due to the varying construction methods and materials.

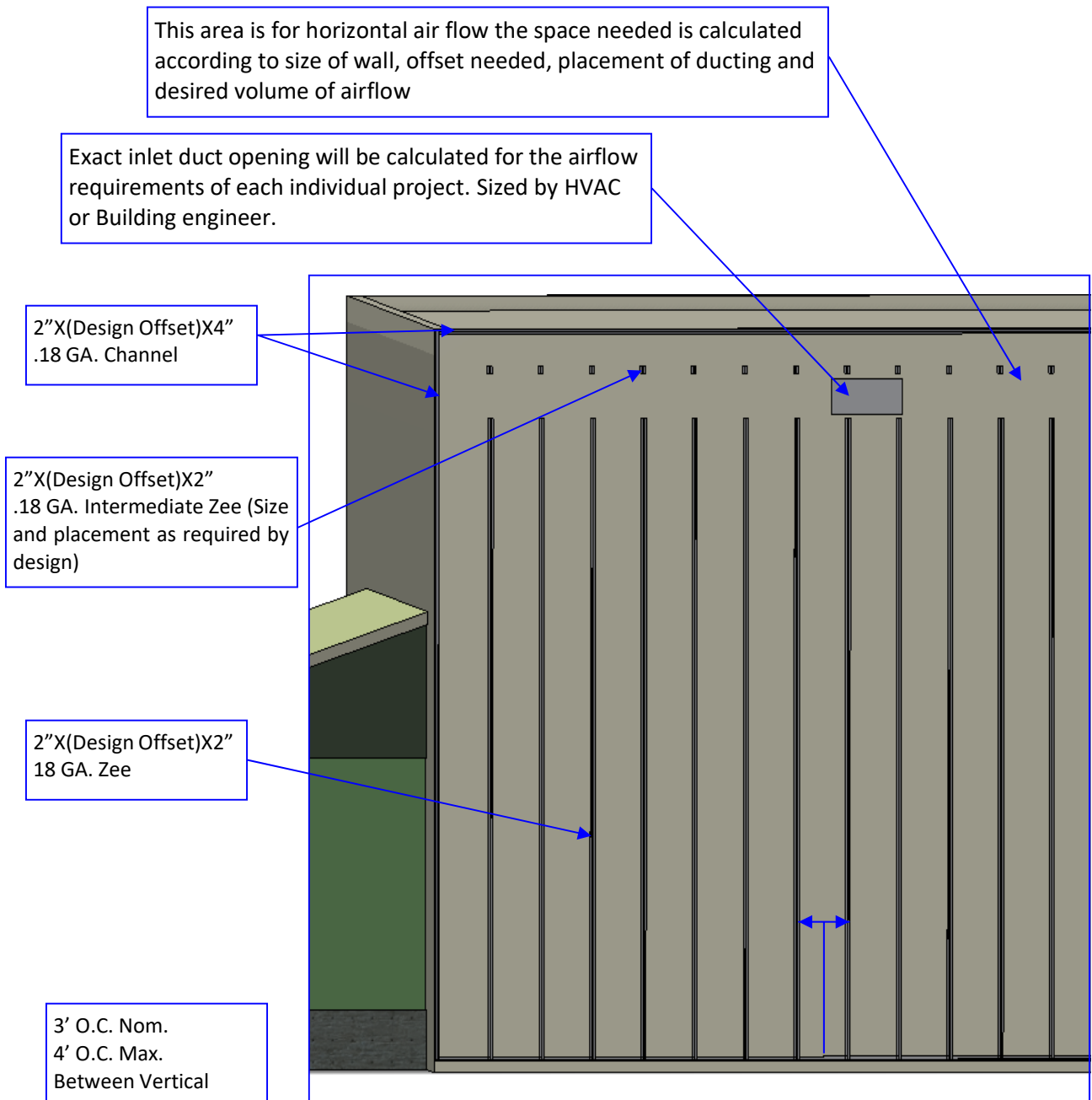

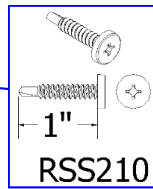
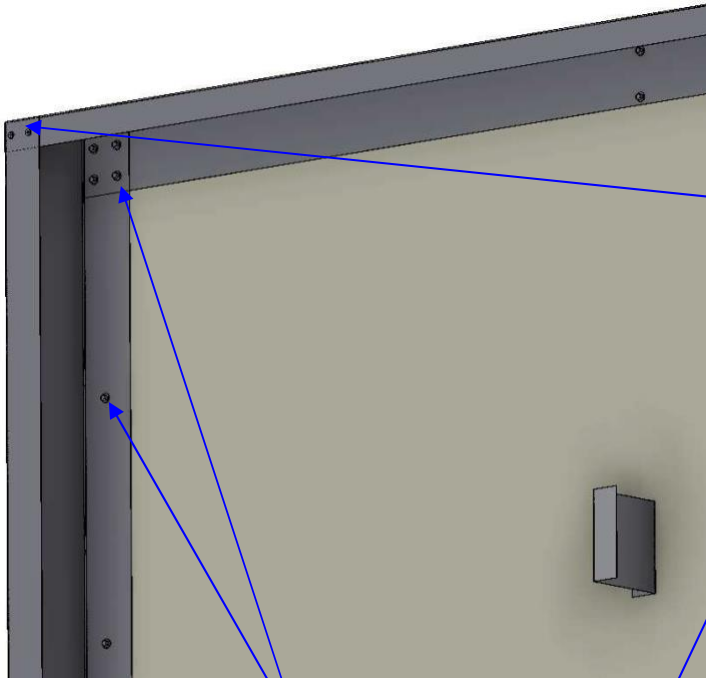

Use the RSS210 fasteners anywhere there is an overlap that needs to be secured that a standard hex head type fastener will create clearance issues with other layers of the construction sequence.

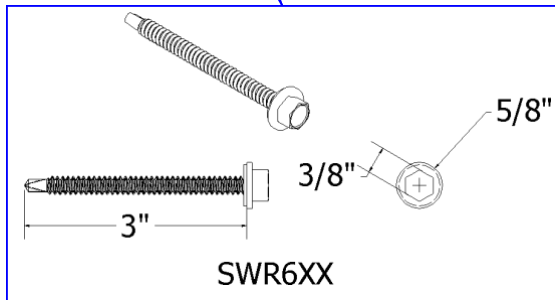
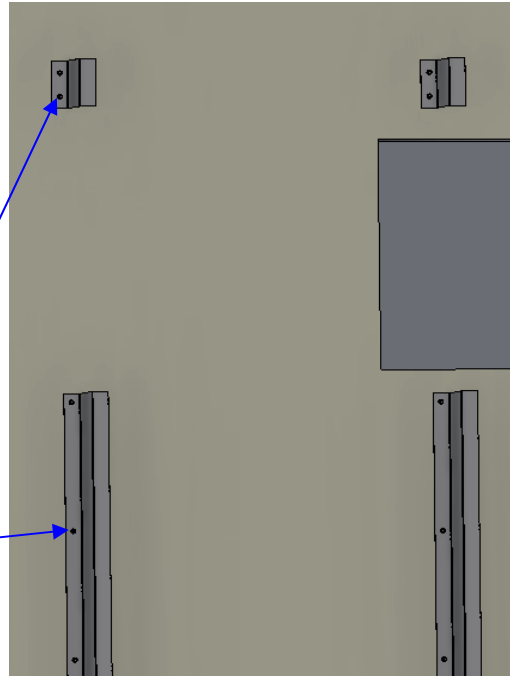

Use the SWR6XX fastener or whatever the appropriate anchor fastener should be according to the building wall and siding construction materials and frame-work. There is NO standard fastener due to the wide range of construction methods and siding materials used.

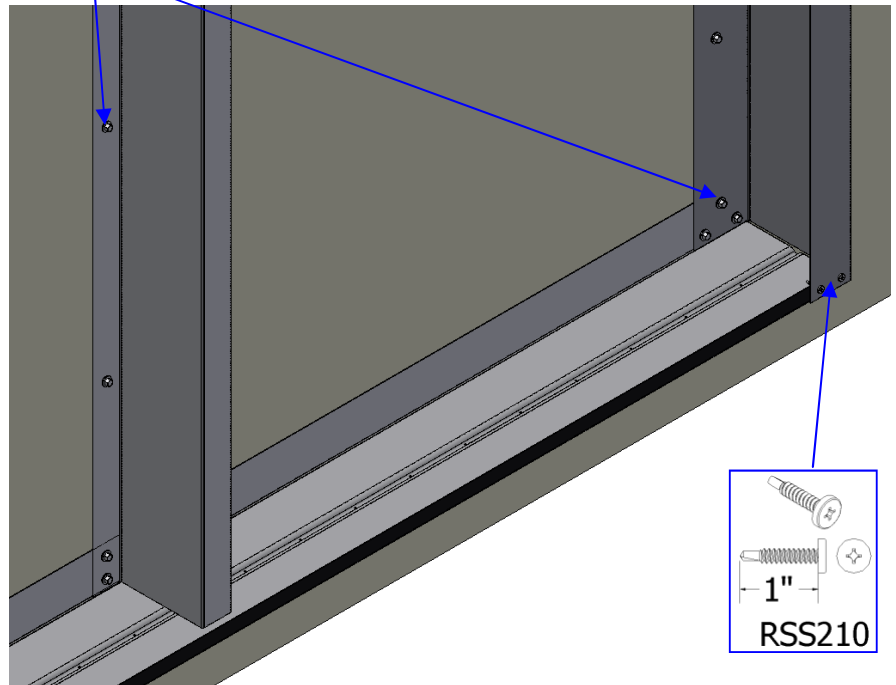

Horizontal framing

The next phase of construction in the vertical panel installation is to fasten the horizontal hat framing sections to the zees that have been fastened to the wall surface or framing members. All these framing members are designed to create an offset of the InSpire Wall system with the proper calculated depth for each project.

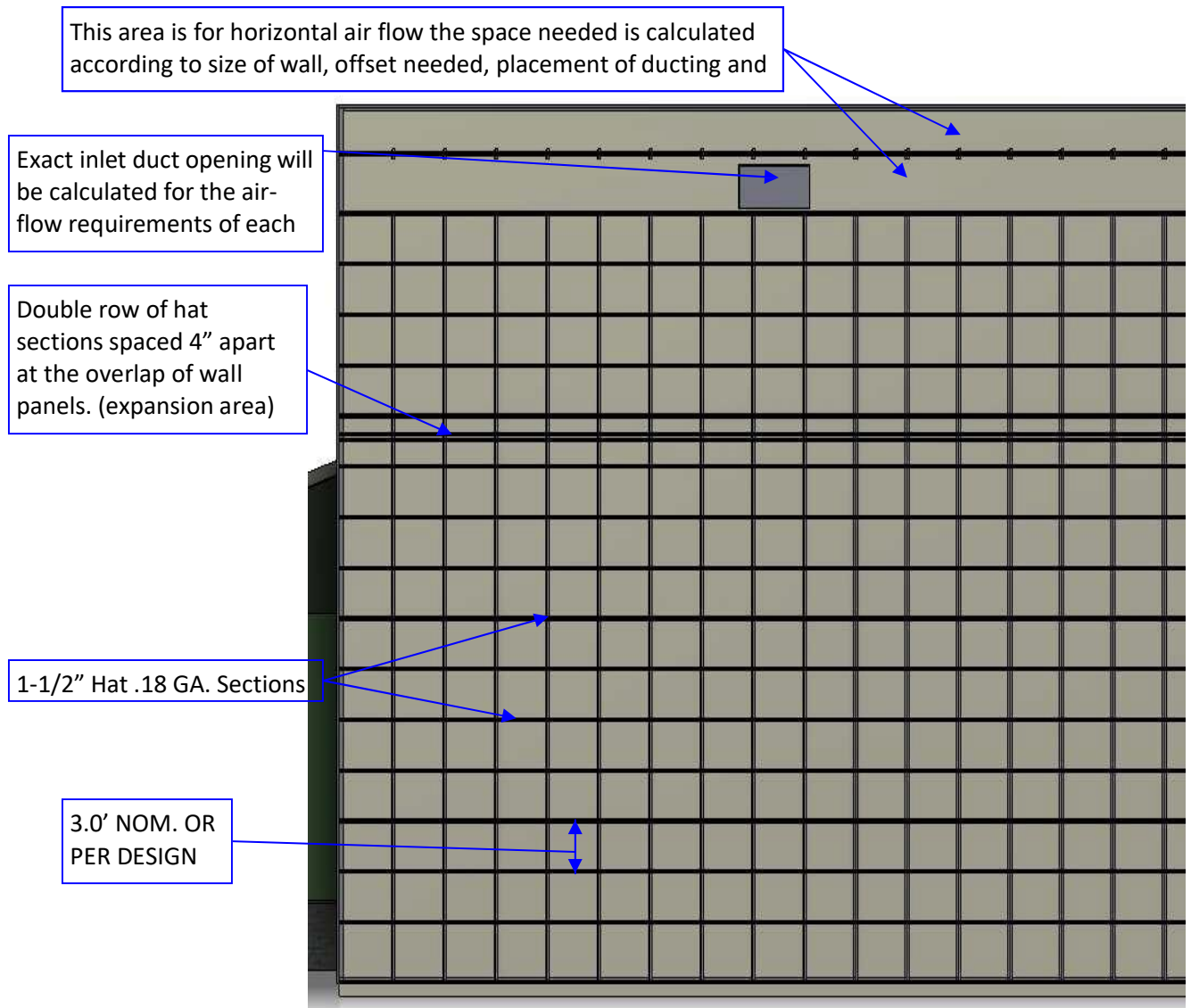

Hat sections should be spaced no more than 4' O.C Max. 3' O.C. is preferred.

Fasten the hat sections to the zee sections with 2-#12 HWH tek screws at each zee. A double row of hats will be needed at any overlapping areas in the wall InSpire panels. Wall panels have a maximum recommended height of 25' because of the amount of expansion they will have during hot and cold temperatures.

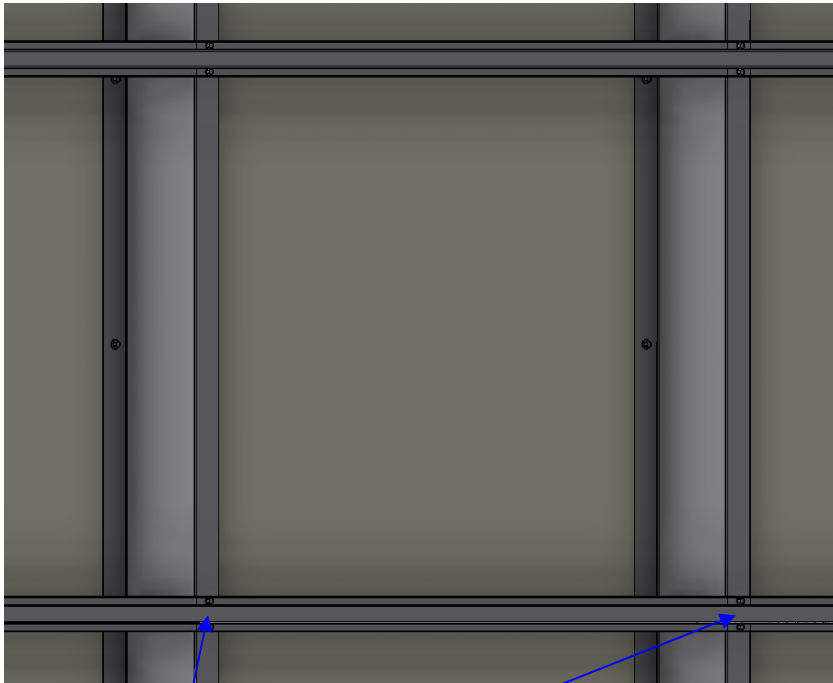

Two RSS014 fasteners are to be used where the horizontal hat framing connects to the vertical Z framing.

The hat framing members are in front of the Z framing but they slip behind the outside perimeter C channels and should be fastened with RSS210 fasteners so there will be no interference of a bolt head with the next step of the installation.

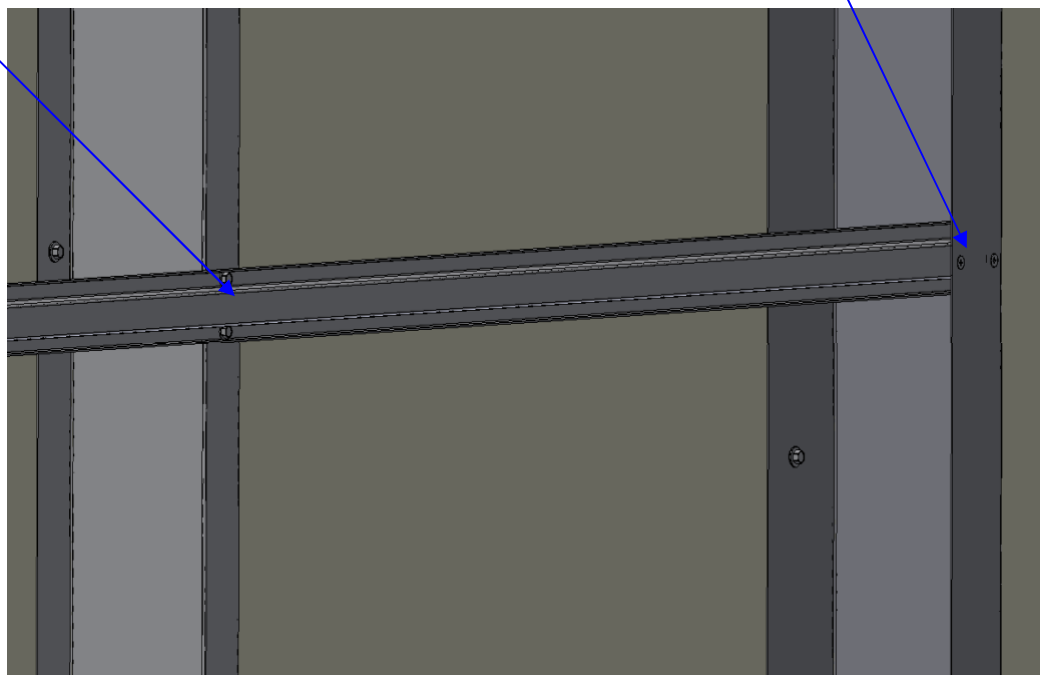

Use 1"X3"X1" C channel to fabricate the frame for the summer bypass louvers if your project has them. The ends will need to be cut as the detail to the right shows.

1"X3"X1" C CHANNEL

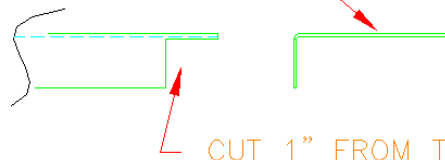

CUT 1" FROM THE LEGS AT THE END OF THE CHANNEL

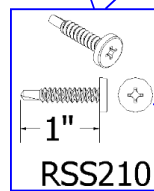
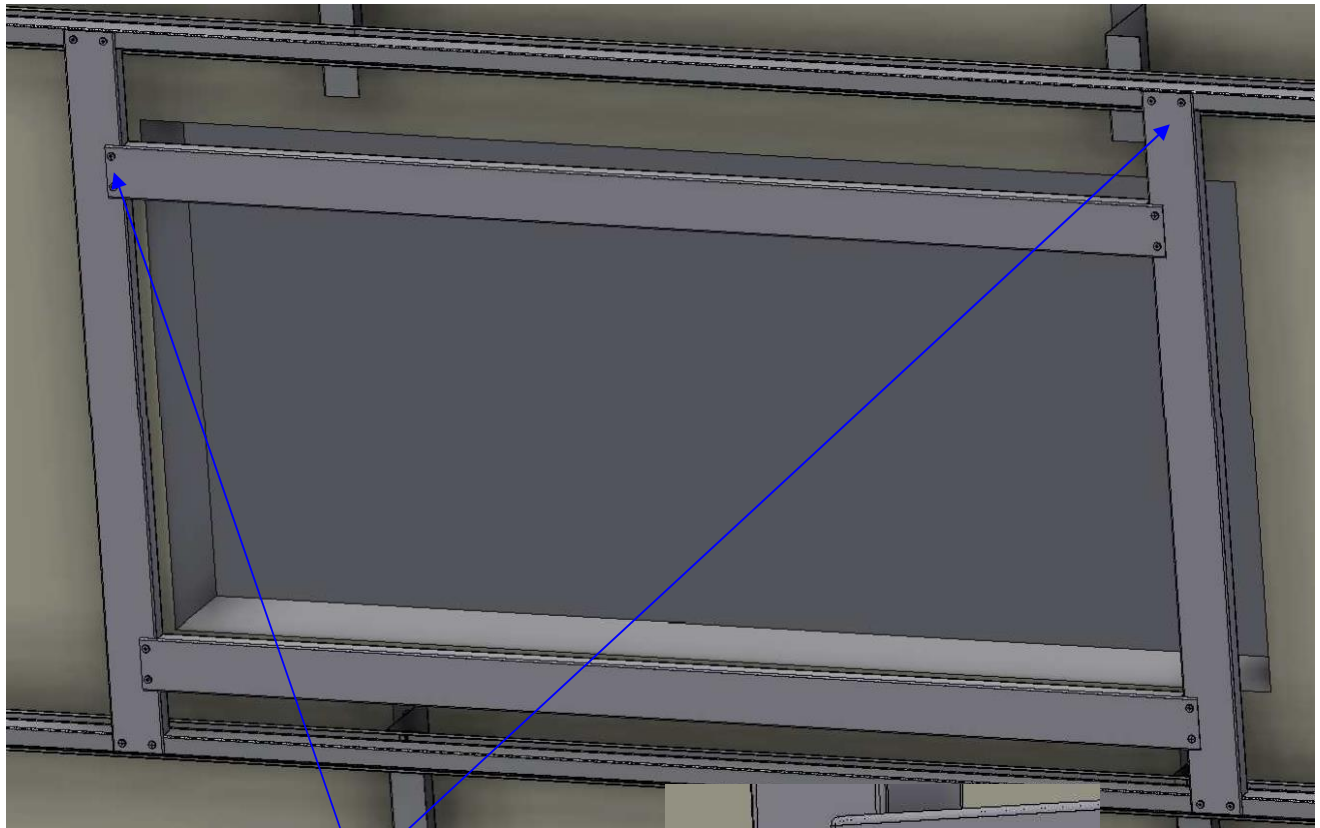

Fasten the assembly to the previous vertical or horizontal framing as need with RSS210 fasteners so there will be no interference of a bolt head with the next step of the installation

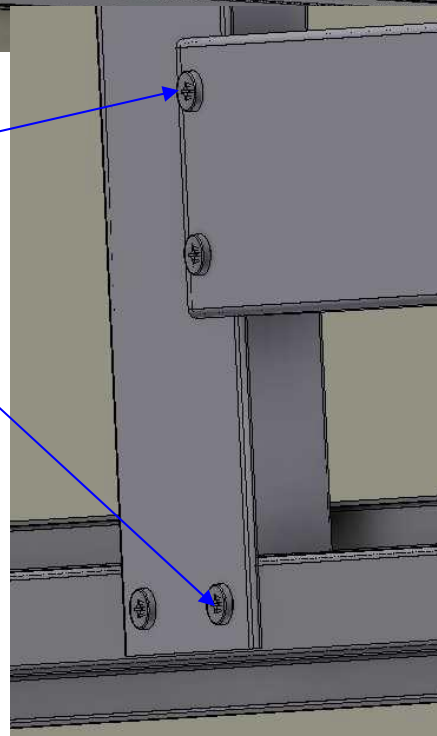

Positioning of InSpire Wall Panel.

Before the InSpire panels go on install the bottom flashing and the butyl tape. These measures to seal the InSpire wall system are integral to its efficiency. Fasten the InSpire Wall Panels to the framing hat sections with stitch screws. Start by fastening the base end of wall panels and work toward stop allow end to be free for expansion. Fasten panels with stitch screws 3' O.C.

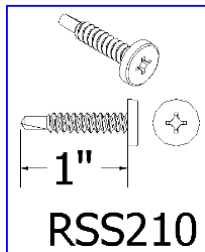
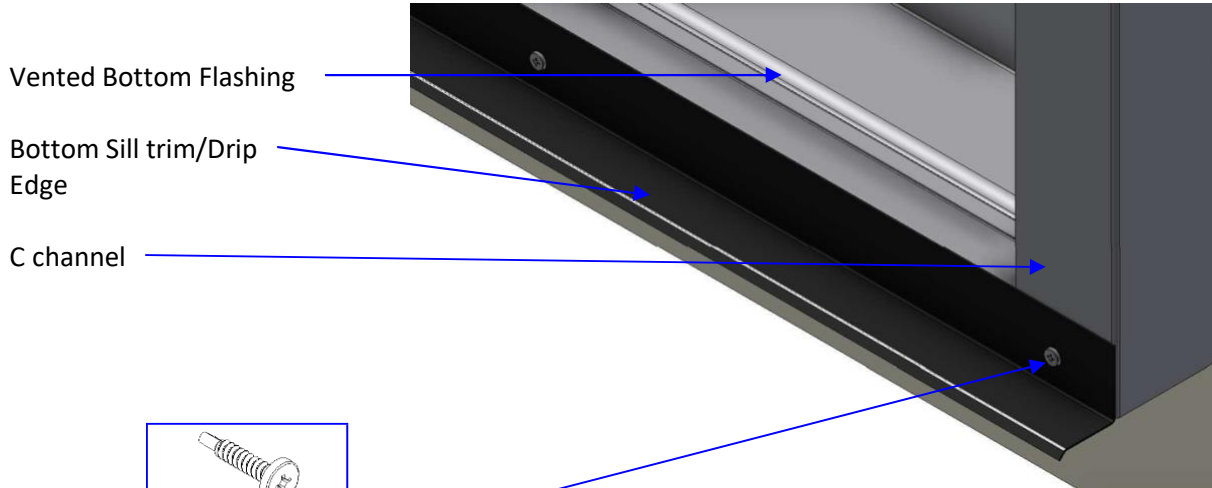

Next install the bottom row of wall panels as tightly on the sill trim as possible. Use SWR8XX fastener with rubber washer every low spot on profile at the top C, the bottom vented flashing and at every hat location.

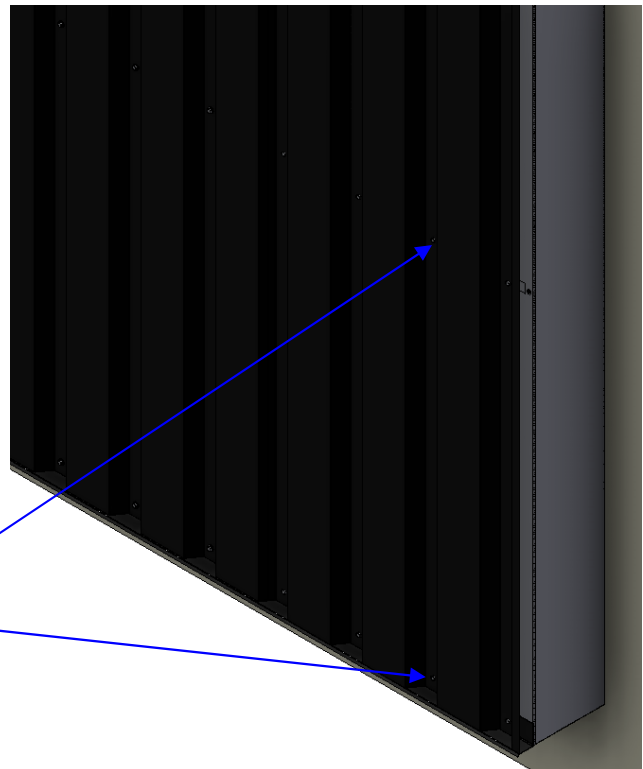
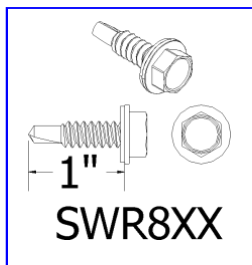



**Expansion
Overlap Detail**
(also see pg. 5)

Notice how the foam matches the profile of the perforated wall panel.

Notice in these two blow up views of the panel lap that the lower panel is fastened to the lower hat section and the top is not fastened at all.

The upper panel is then lapped over the bottom and fastened to the upper hat section leaving the bottom free.

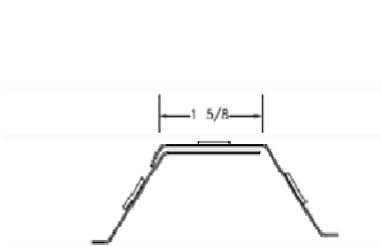

Panel Lap Detail

Also note the horizontal panel over-lap. The vertical seam on the lower panels does not continue to the upper panels.

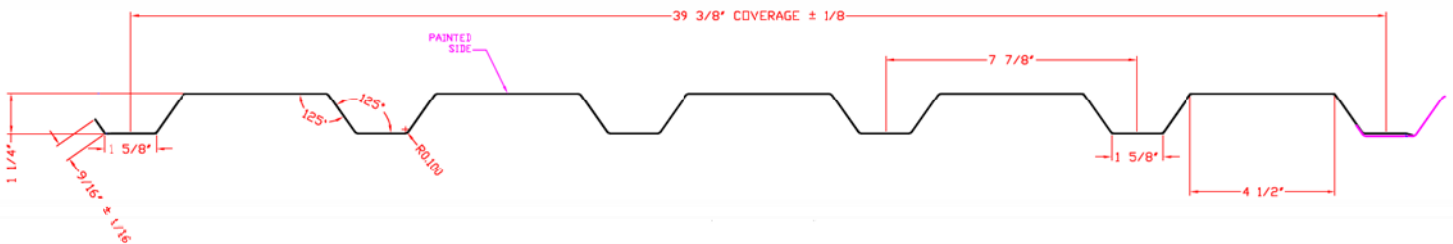
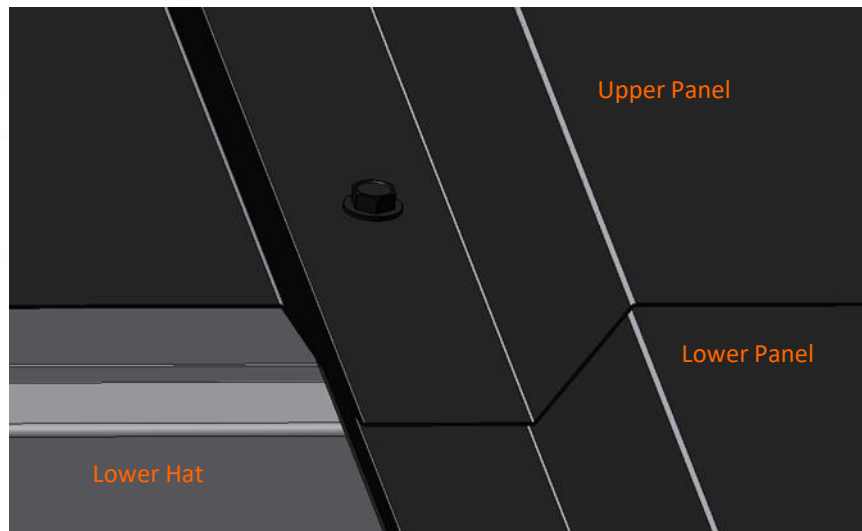

Panel Coverage Detail

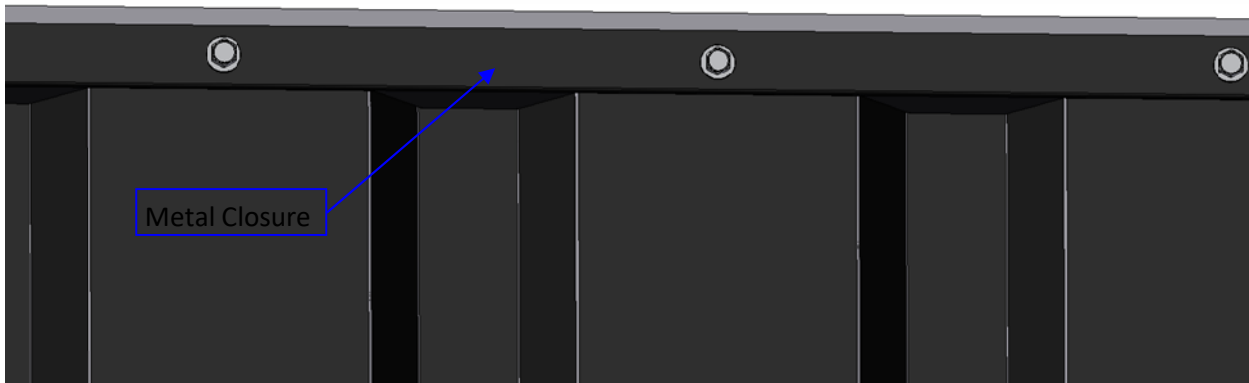
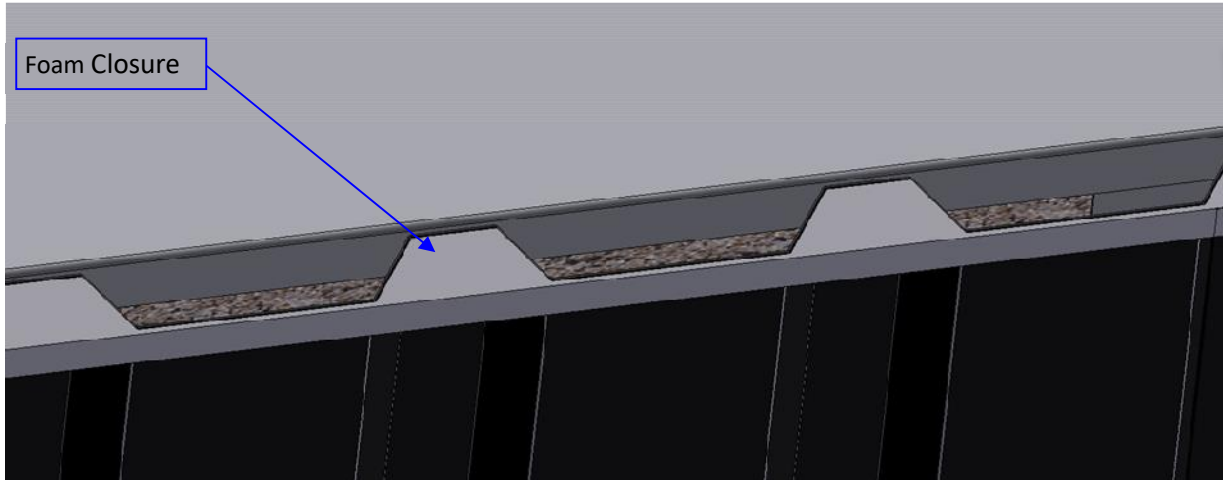

Top detail

Detail shown without flashing or top treatment to reveal the neoprene foam closure

Flashings and trims

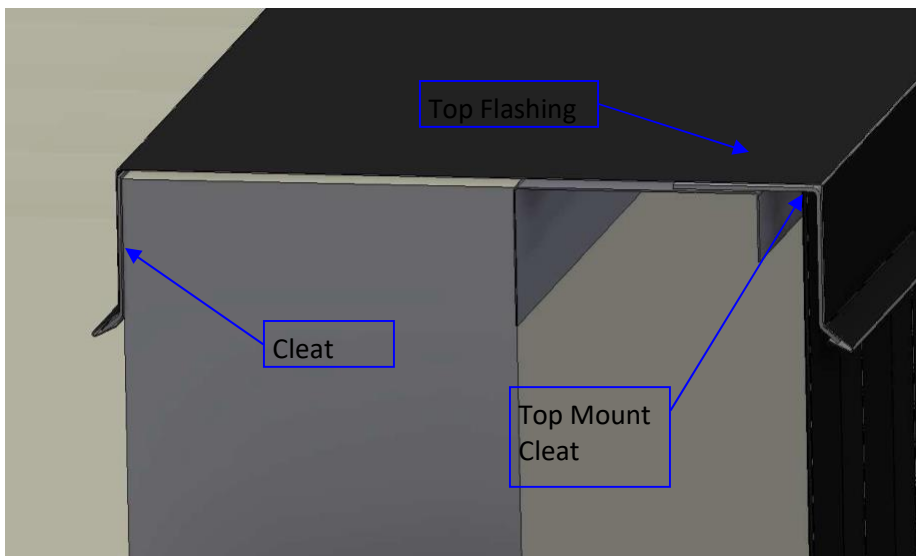

Note this is just one of many different roof treatments. Actual roof integration will be better defined by the construction drawings of the building the InSpire wall system is to be installed on.

SEE: Top Flashing Detail for fastening.

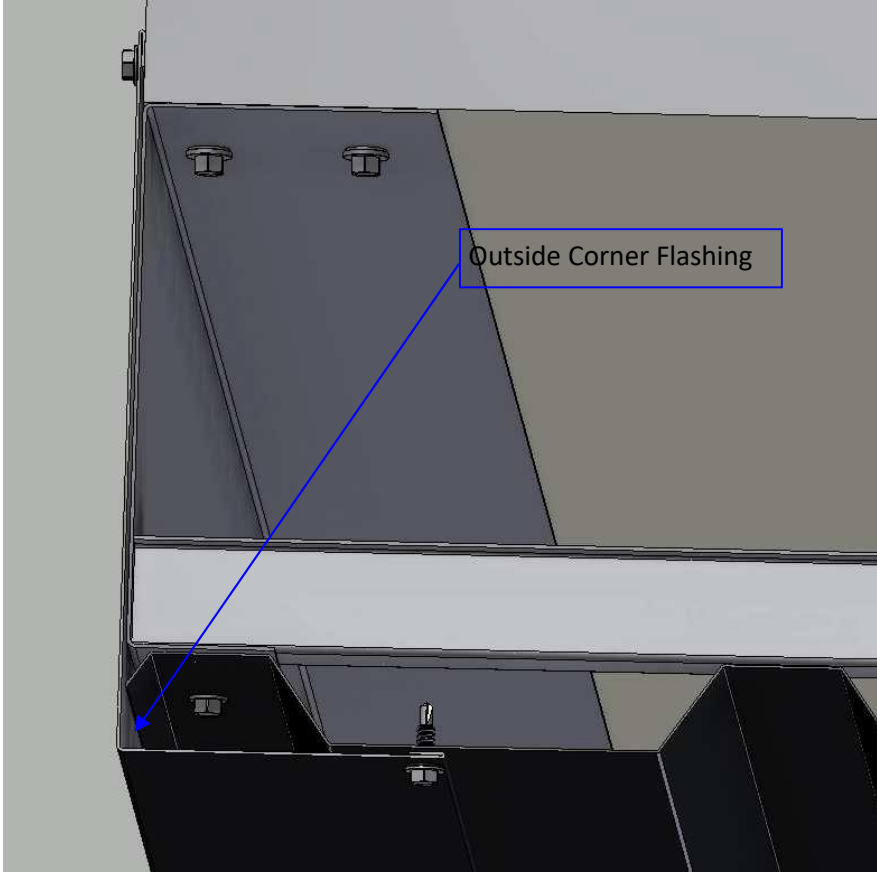

Install end and outside flashings over top C framing with an adequate overlap of existing building and the cut end of the InSpire panels so that there is room to securely fasten the flashing as shown.

There are many different wall systems and ways of fastening and flashing to them. Please be careful to follow the shop drawings and details for your individual job.

The inspire wall system is sensitive to pressure drops and must be sealed according to the detail drawings wherever necessary.

SEE: corner and end details

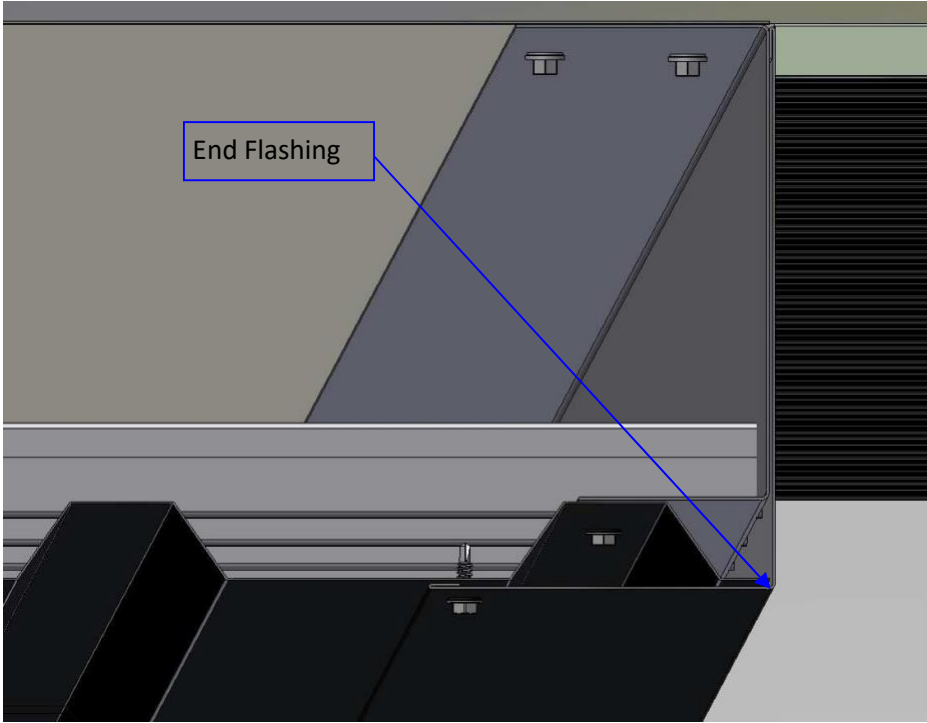

Flashing louvered vent starts with the foam closure at the bottom.

Then install the bottom flashing over the foam closure and fasten securely to create a seal.

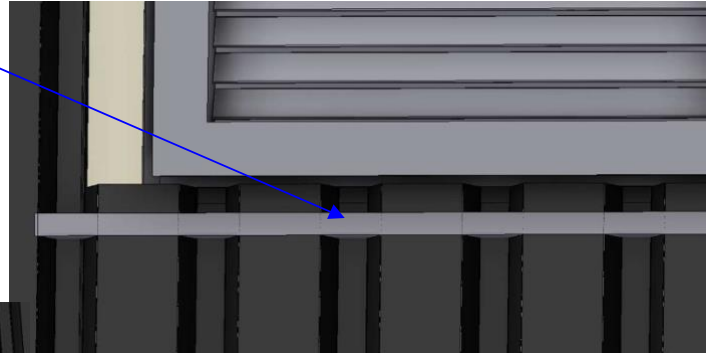
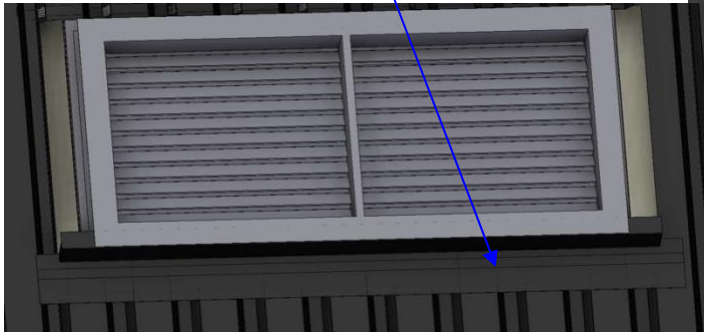

The side flashing follows and must be wide enough to cover and enclose any motor/actuator mechanism. This should be planned out before the flashing is started to make sure the bottom and side flashings will work together and seal correctly.

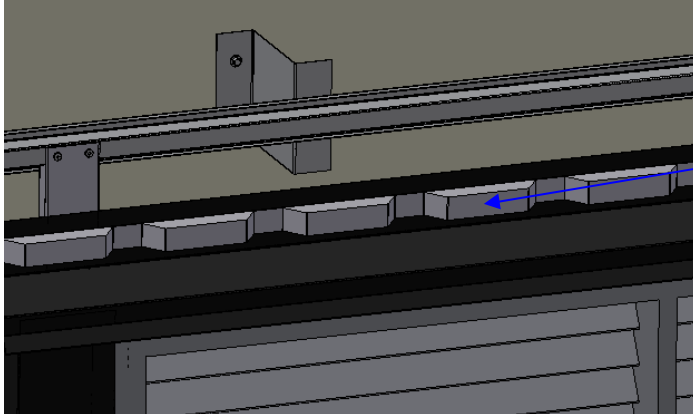
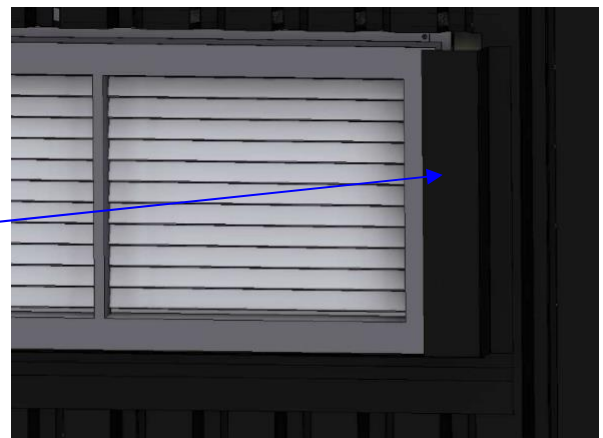

Next comes the top flashing. Insert a foam closure strip in front of the flashing, behind the InSpire wall panels to insure a seal.

When finished all corners should be clean looking and sealed with the appropriate sealant. Any air leakage around flashing or trim will reduce the walls efficiency.



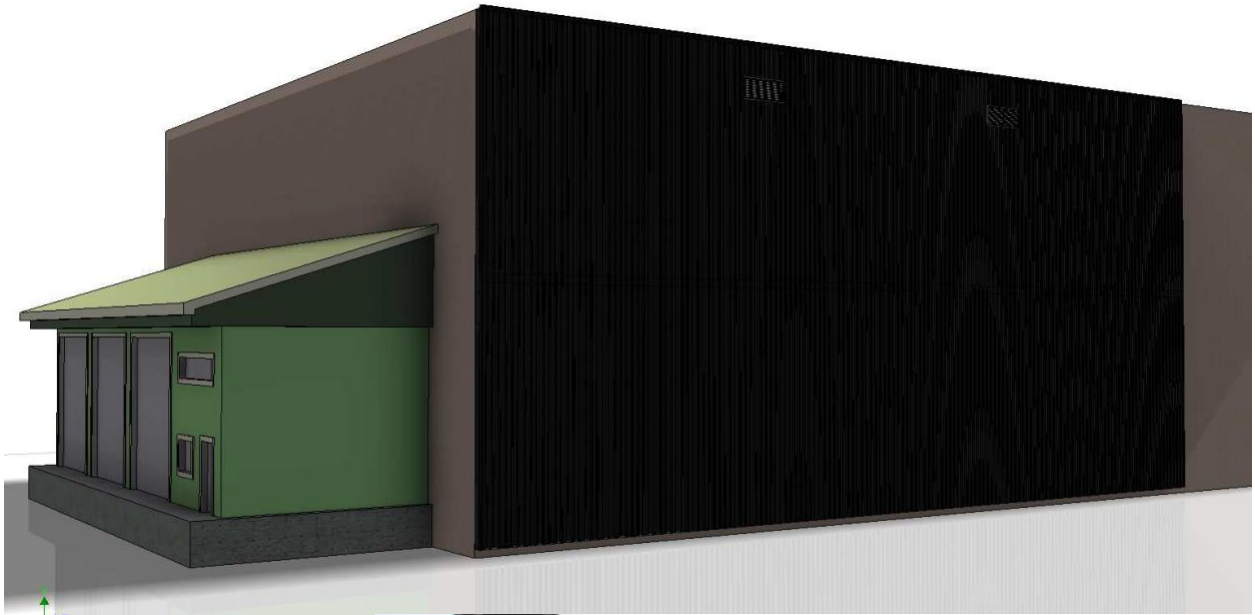

Picture and Rendering show the finished installation of InSpire wall system.



Fixing the product label on the collector

Once installation is finished, the product label – provided by ATAS upon delivery - must be screwed on the lower end of the collector, so it can easily be visible.



EXTRA PRECAUTIONS FOR INSPIRE HP PANELS

The InSpire HP panel has high heat retaining properties and therefore extra care must be taken before and during installation.

Receiving and storage

Upon delivery, the InSpire HP panels are protected with a plastic film to avoid scratches prior to installation. If exposed to sunlight, the top panels on the crating may heat up and damage and dry out the protective film on the panel's treated surface.

To avoid this, make sure the InSpire HP Panels are stored inside or in a completely shaded area. If this is not possible and the panels are stored outside, they need to be completely covered with an opaque tarp.

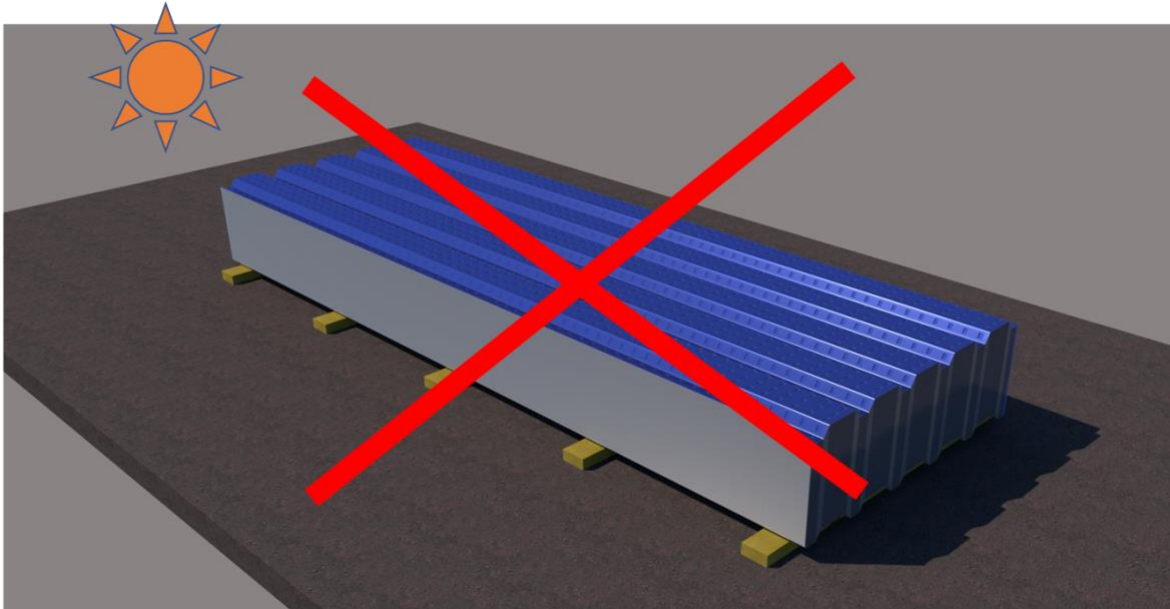

InSpire panels shall never be exposed to sunlight prior to installation

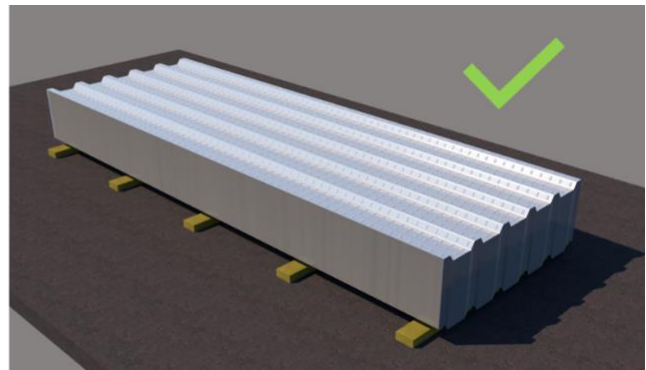
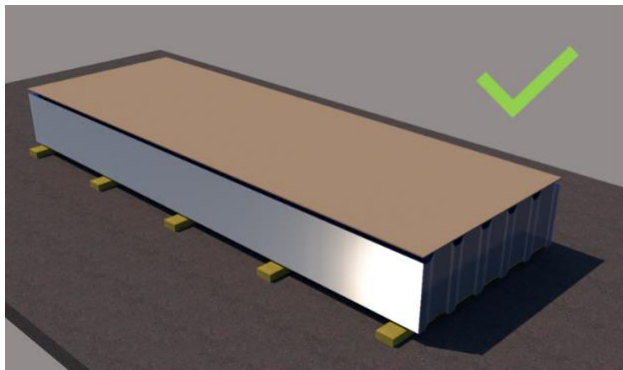

InSpire panels shall be protected from sunlight with a stable opaque covered or be stored with the treated colored surface face down

Panels on the ground during installation

Treated surface of the InSpire HP panel shall continue to be protected on the day of installation, especially if installation work takes place in sunny conditions, as damage of the protective film can occur within a few minutes of exposure.

Precautions shall also be taken when the panels are laid on the ground prior to being lifted and fastened on the wall.

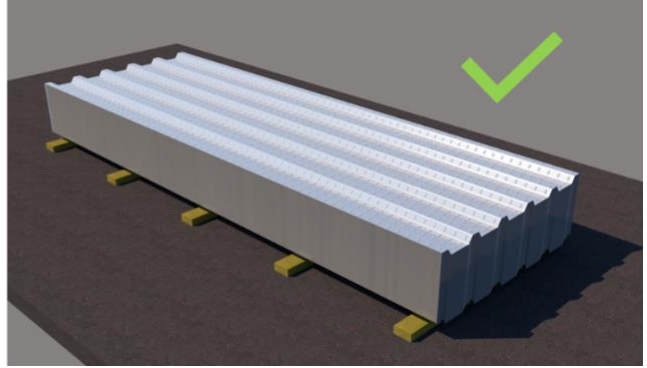
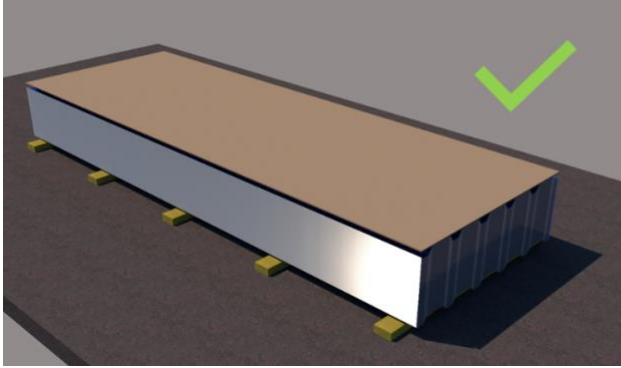

InSpire panels shall be protected from sunlight also during installation

Removal of protective film upon fastening on the wall

Installers shall keep delay of exposure of the plastic film to a minimum.

Method 1: removing film on the ground.

On the ground, once the plastic film is removed from the panel, it must be mounted carefully into final vertical position.

Note that the InSpire HP treated surface scratches more easily than traditional coating materials (such as InSpire traditional PVDF finish).

Extra care must therefore be taken while positioning and fastening the panels to avoid scratches.

This method should on windy days.



Method 2: removing film on the vertical wall

One way to ensure protection of the InSpire HP treated surface during installation is to proceed as follows:

- Vertical positioning of the panel, including overlap over the previously installed panel;
- Inserting two holding screws the top of the panel and, once in place;
- Removal of the protective film by pulling it downwards.

