

1. PRODUCT NAME

LINEAIR OPALINE™ IN CARRIER
OPF, OPN, OPM, OPW

2. MANUFACTURER

ATAS INTERNATIONAL, INC.
Website: www.atas.com
Email: info@atas.com
Corporate Headquarters:
Allentown, PA 18106
Phone: (800) 468-1441

3. PRODUCT DESCRIPTION

Basic Uses:

Opaline panels have a smooth appearance with a concealed clipless fastening system. These panels are typically used for both interior and exterior walls and ceilings, either direct mount or suspended. Carrier is manufactured in .040 aluminum for suspended snap in applications.

Composition & Materials:

Standard Offerings: Opaline panels are formed from .032 and .040 aluminum (except OPM045); Special Offerings: 16 oz. or 20 oz. copper may be specified, subject to minimum quantities and lead time.

Sizes:

The OPM045 is a 4½" panel with three 1" wide ribs, 1½" on center. OPF040, OPF060 and OPF080 are 4", 6" and 8" wide panels that create a flush surface. OPN041, OPN061 and OPN081 are 4", 6" and 8" panels with a 1" raised rib. The OPW045, OPW065 and OPW085 are 4½", 6½" and 8½" wide panels with a ½" reveal. Panel lengths are cut to customer specifications, with a minimum of 2' to any transportable length. The OPW and OPF panels produced from .032 aluminum can be lanced for ventilation.

Colors & Finishes:

A choice of over 40 stock colors is available in a 70% PVDF finish. (Request color chart or chips). Custom colors available. An anodized finish is available in Clear Satin, Dark Bronze LA Extra Dark Bronze or BlackMatt. Texture may be smooth, stucco embossed, or wood grain embossed (available in 24 ga. metallic coated steel, .032 aluminum & .040 aluminum only). The panel is also available louvered, vented, or perforated. Micro perforations with or without Soundtex® backing.

4. TECHNICAL DATA

70% PVDF based finishes tested by paint supplier for:

- Dry Film Thickness: ASTM D 1005, ASTM D 1400, ASTM D 4138 or ASTM D 5796
- Specular Gloss: ASTM D 523
- Pencil Hardness: ASTM D 3363
- T-Bend Flexibility: ASTM D 4145
- Mandrel Bend Flexibility: ASTM D 522
- Impact Resistance: ASTM D 2794
- Adhesion: ASTM D 3359
- Water Immersion Resistance: ASTM D 870
- Abrasion Resistance: ASTM D 968
- Acid Resistance: ASTM D 1308

- Acid Rain Resistance (Kesternich): ASTM G 87 or DIN 50018
- Salt Spray: ASTM B 117
- Cyclic Salt Spray: ASTM D 5894 and ASTM D 5487
- Humidity Resistance: ASTM D 2247
- Accelerated Weathering: ASTM D 822 and ASTM G 23, ASTM G 151 or ASTM G 153
- Color Retention, Florida Exposure: ASTM D 2244
- Chalking Resistance – ASTM D 4214
- Cleveland Condensing Cabinet: ASTM D 4585
- Cure Test, MEK Resistance: ASTM D 5402
- Alkali Resistance, Sodium Hydroxide: ASTM D 1308, Procedure 7.2
- Organic coatings meet requirements of AAMA 2605 when applied to aluminum.

Panel testing/ratings:

- Galvanized Steel: ASTM A 653
- Aluminum: ASTM B 209
- Coil Coating: ASTM A 755
- Field Tested and Approved.
- Load Tables available upon request.

5. INSTALLATION

A suspended ceiling carrier is pre-punched and rollformed from prepainted .040 aluminum. The standard length of the carrier is 12'. The carrier is suspended by wire or strips, or attached directly to the substructure, and the panel is snapped on the carrier. 1/8" space should be allowed between panels for thermal movement along the panel length. For acoustical efficiency, fiberglass insulation may be placed across the top of the panels between the carriers. Installation details or hands-on training through our seminars are available through ATAS. Visit www.atas.com for more information.

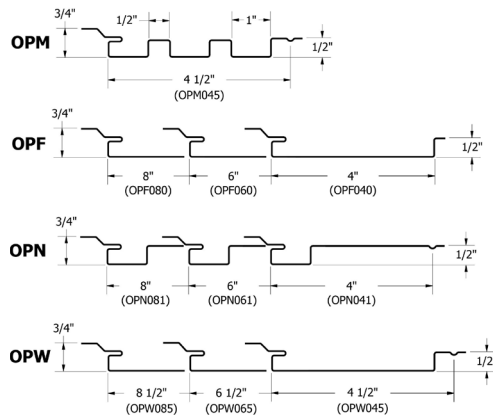

Flush Lineair Opaline (OPF) Ceiling with Snap In Carrier

6. AVAILABILITY & COST

Availability:

Lineair Opaline panels are available through ATAS product distributors. A complete line of related components and trim accessories is available to complete the wall system. In addition, a complete line of rainware and perimeter roof edge trims can be supplied by ATAS to complete the wall system. Flat sheet and/or coil stock are available in matching color for fabrication of related components by the installing contractor.

Cost:

Contact ATAS product distributors for current pricing.

7. WARRANTY

Products coated with a fluoropolymer, 70% PVDF finish carry a limited warranty against chalking and fading.

8. MAINTENANCE

Opaline panels require minimal maintenance. Surface residue may be easily removed by conventional cleaning methods. Minor scratches should be touched up with a matching paint, available from the manufacturer.

9. TECHNICAL SERVICES

Complete technical information and literature are available at www.atas.com. ATAS will assist with design ideas and shop drawings.

10. FILING SYSTEM

- www.atas.com
- Additional product information is available from the manufacturer upon request.

