

**MFF120**

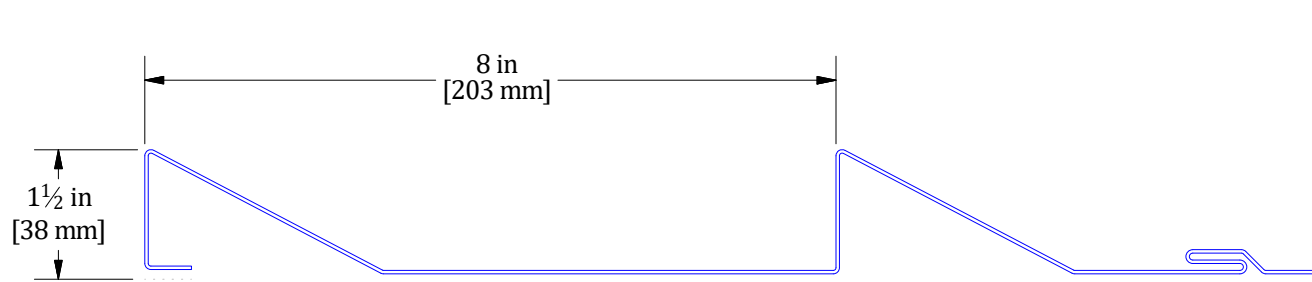

**MFF121**

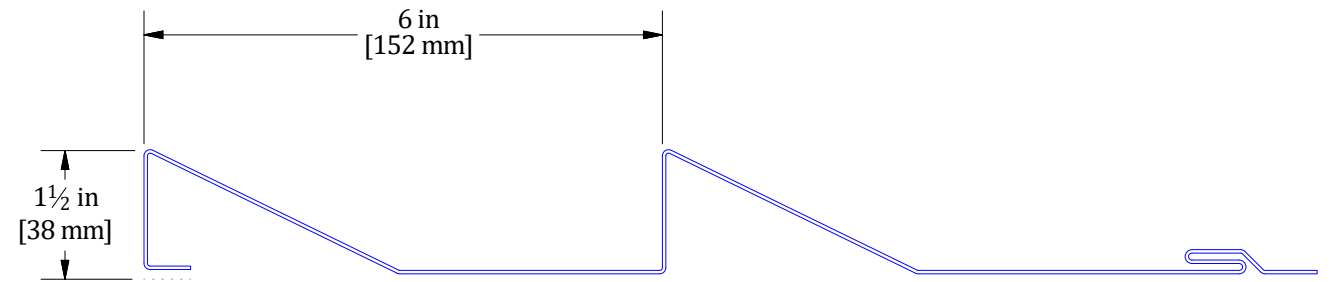

**MFF123**

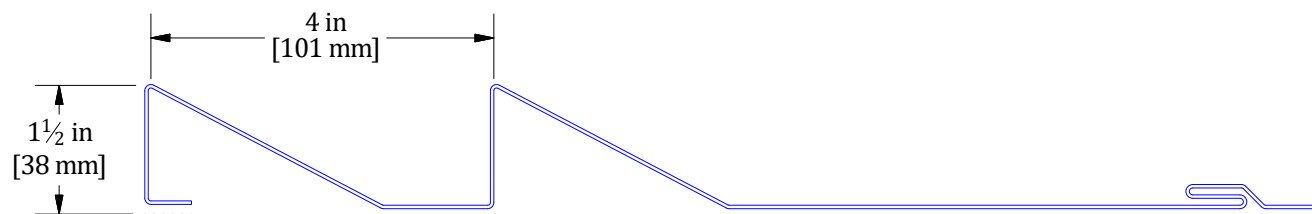

**MFF122**



**MFF124**

**Notes:**



DWG TITLE:		Panel Profiles	
DWG No:		DWG BY:	M.L.P.
		DWG DATE:	4/30/2026
APP BY:	D.S.	APP DATE:	4/30/2026
PANELS/PRODUCT:		SHEET SIZE:	B
(MFF) MultiFin		SCALE:	X : X

REV. NO.	DATE	DESCRIPTION OF REVISION	BY	APP
0	4/30/2026	Initial Release	M.L.P.	D.S.

# Horizontal Panel

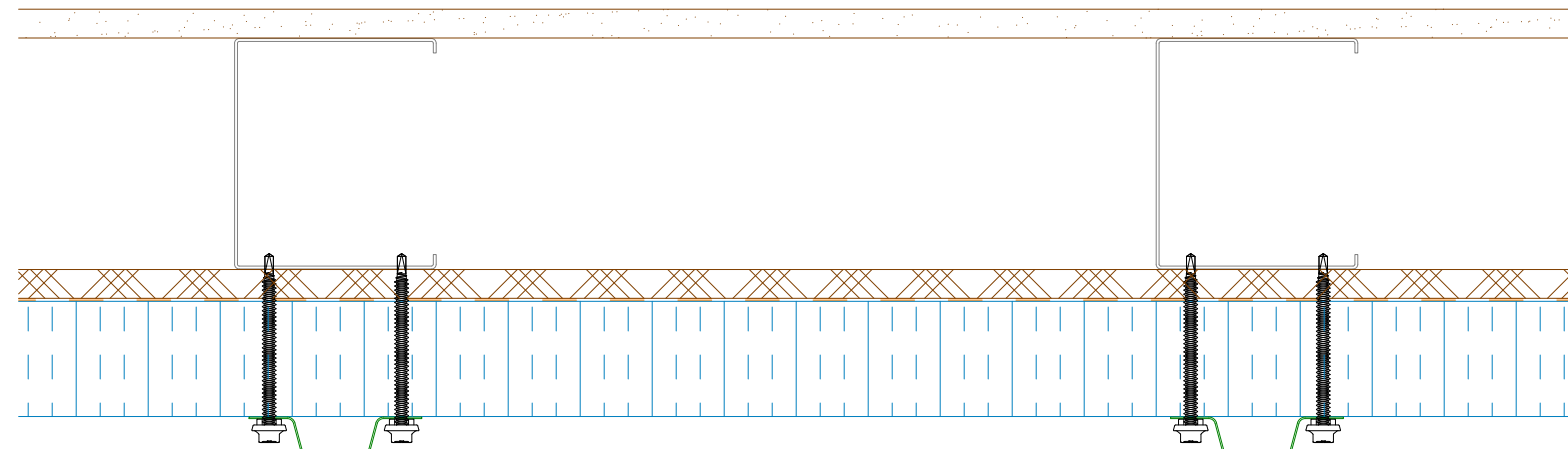
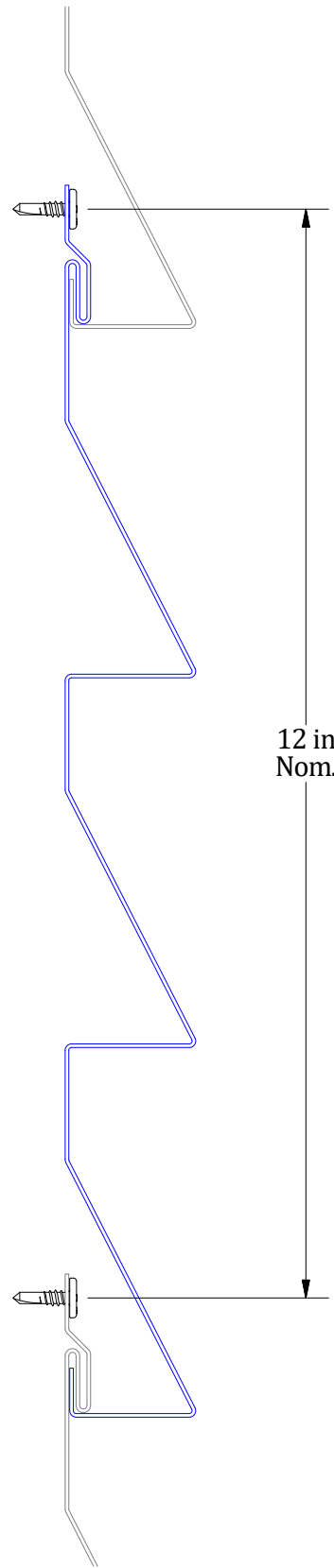

Attach Subgirts into Metal Wall Studs using appropriate fasteners.

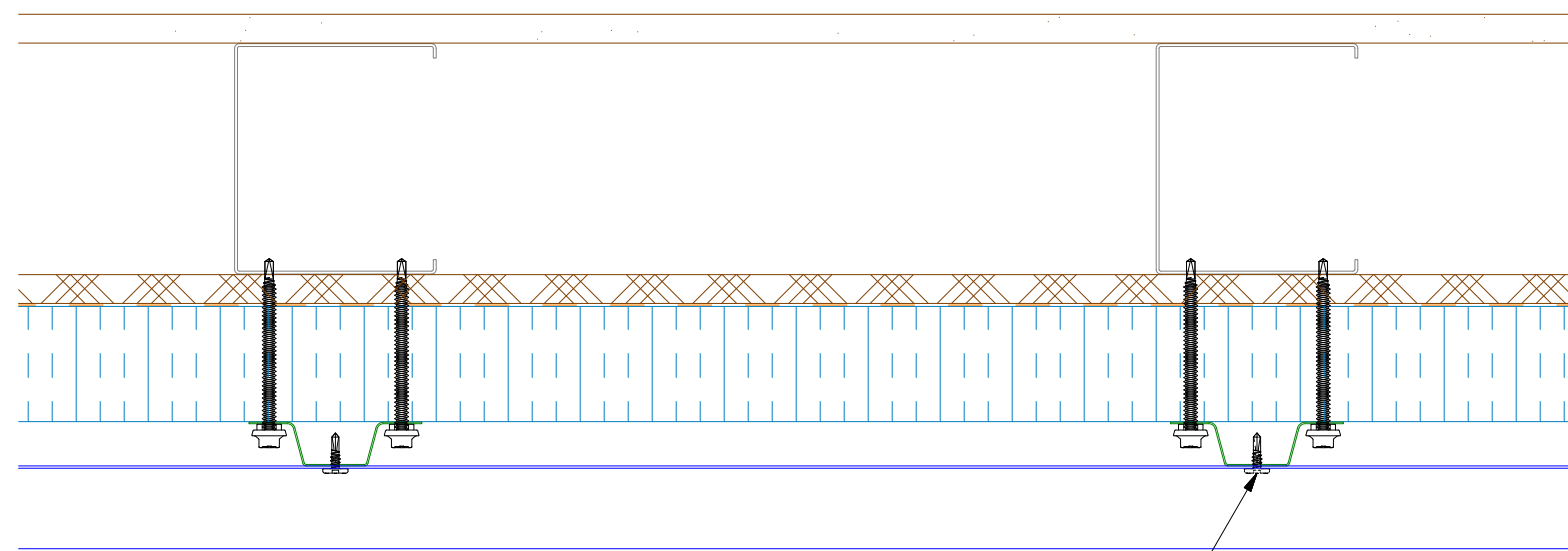

Attach Panel System to Subgirts using #10 x 5/8" Pancake Head Screws.

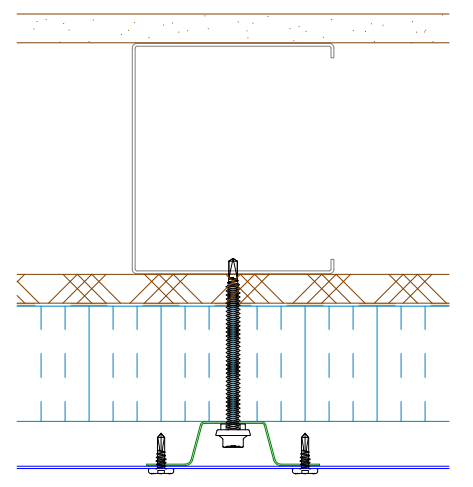
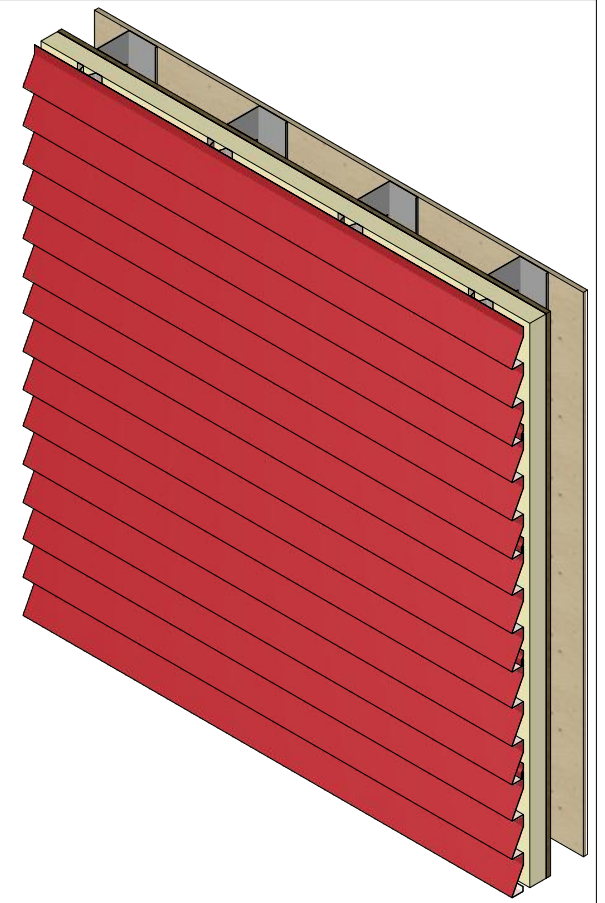

Alternative Subgirt Orientation

**Notes:**

**ATAS International, Inc.**  
 Sustainable Solutions For A Better Future  
 www.atas.com | info@atas.com  
 800.468.1441

DWG TITLE: <b>Open Framing Installation Detail</b>	
DWG No: M.L.P.	DWG DATE: 5/1/2026
APP BY: D.S.	APP DATE: 5/1/2026
PANELS/PRODUCT: <b>(MFF) MultiFin</b>	
SHEET SIZE: B	SCALE: X : X

REV. NO.	DATE	DESCRIPTION OF REVISION	BY	APP
0	5/1/2026	Initial Release	M.L.P.	D.S.

Secure Fastener in Center of the Slot  
 Field Pre-Punch Fastener Slots to allow for Panel Expansion and Contraction

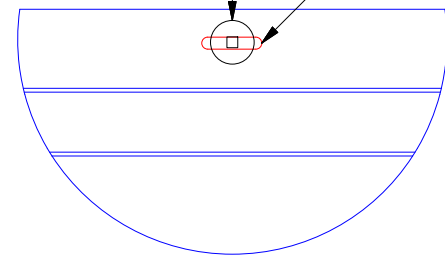

**DETAIL A**

Pin Panel in Center (x3)

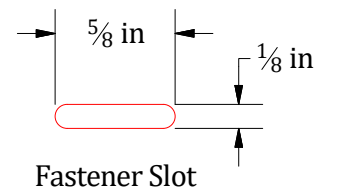
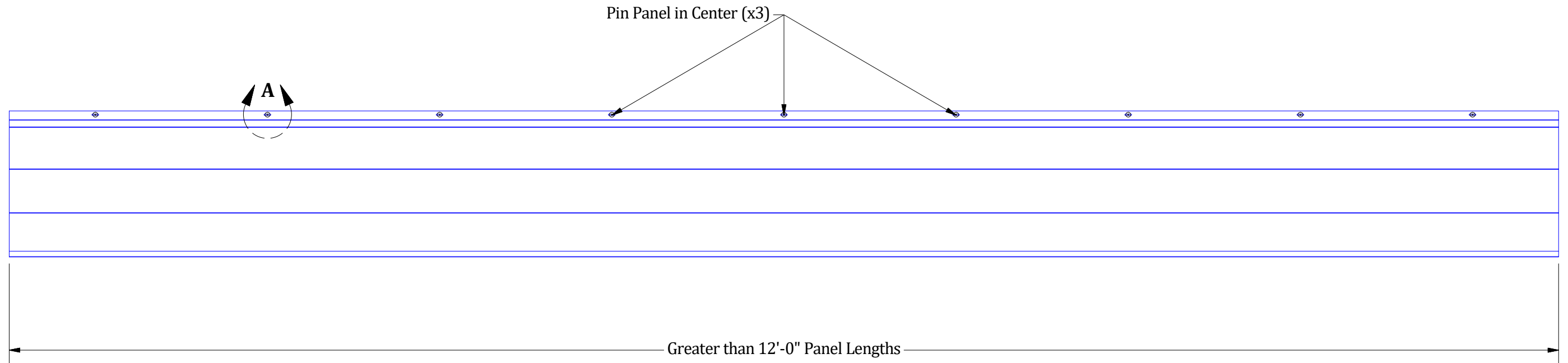

**Notes:**

**ATAS** **ATAS International, Inc.**  
 Sustainable Solutions For A Better Future  
 www.atas.com | info@atas.com  
 800.468.1441

REV. NO.		DATE	DESCRIPTION OF REVISION	BY	APP	DWG TITLE: <b>Panel Fastening Slot Detail</b>	
0	4/30/2026	Initial Release		M.L.P.	D.S.	DWG No.	
						PANELS/PRODUCT:	<b>(MFF) MultiFin</b>
						DWG BY:	M.L.P.
						APP BY:	D.S.
						DWG DATE:	4/30/2026
						APP DATE:	4/30/2026
						SHEET SIZE:	B
						SCALE:	X : X

# Horizontal Panel

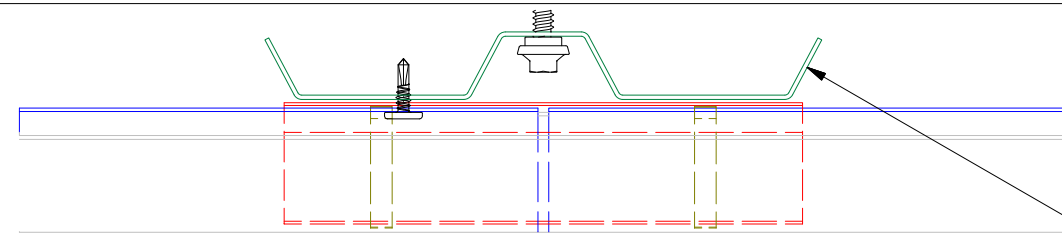

**VIEW A-A**

**M-Channel**  
\*Cut to size of coverage & installed with appropriate fastener.



**Appropriate Fastener**  
\*Fastened through panel, splice and M-Channel

**Non-Hardening Butyl Sealant Bead**

**Stagger Splice Locations**

**Appropriate Gap Range**  
(1/8" - 1/4")

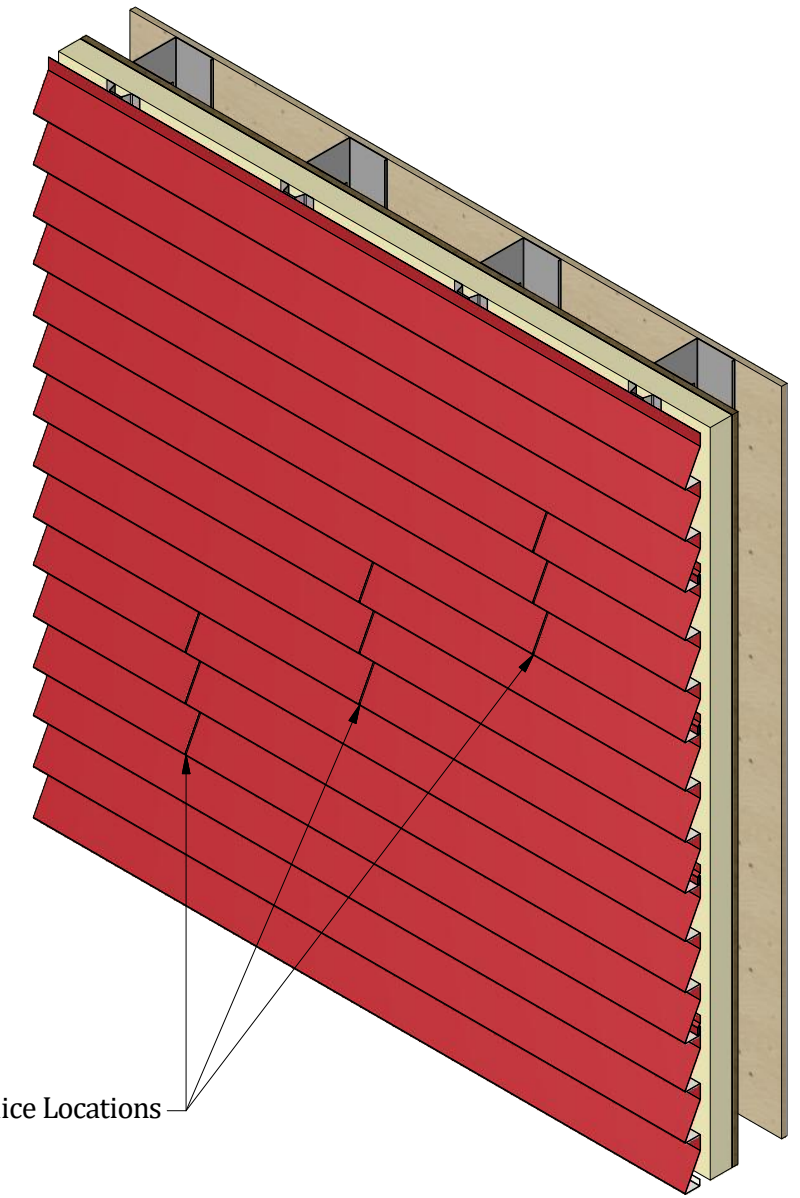
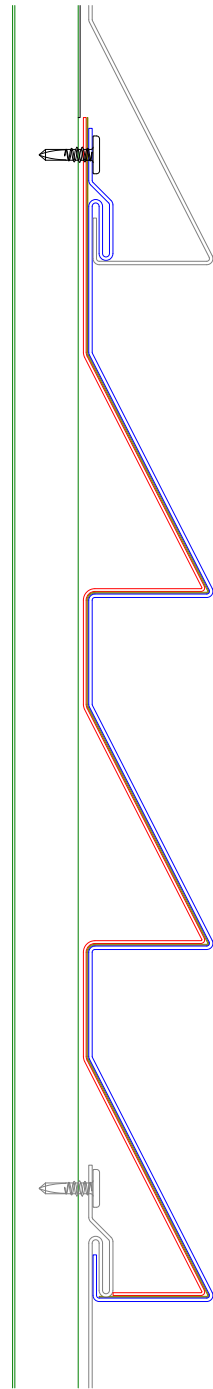

- Notes:**
- 1) \* denotes color side.
  - 2) Splice Profile varies on Panel Profile.

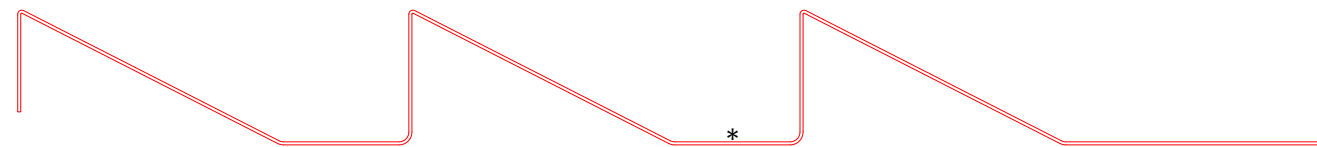

**ATAS International, Inc.**  
Sustainable Solutions For A Better Future  
www.atas.com | info@atas.com  
800.468.1441

**Open Framing Splice Installation**

REV. NO.	DATE	DESCRIPTION OF REVISION	BY	APP	PANELS/PRODUCT:	SHEET SIZE:	SCALE:
0	5/1/2026	Initial Release	M.L.P.	D.S.	(MFF) MultiFin	B	X : X

DWG No.	DWG DATE:	APP BY:	APP DATE:
	5/1/2026	D.S.	5/1/2026

# Horizontal Panel

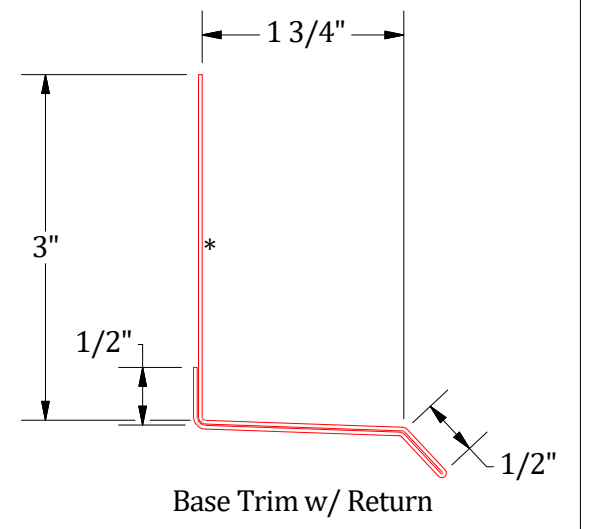
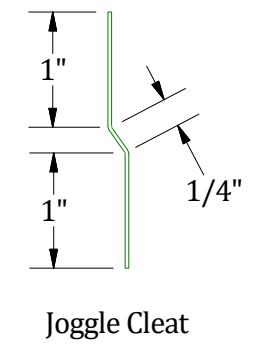
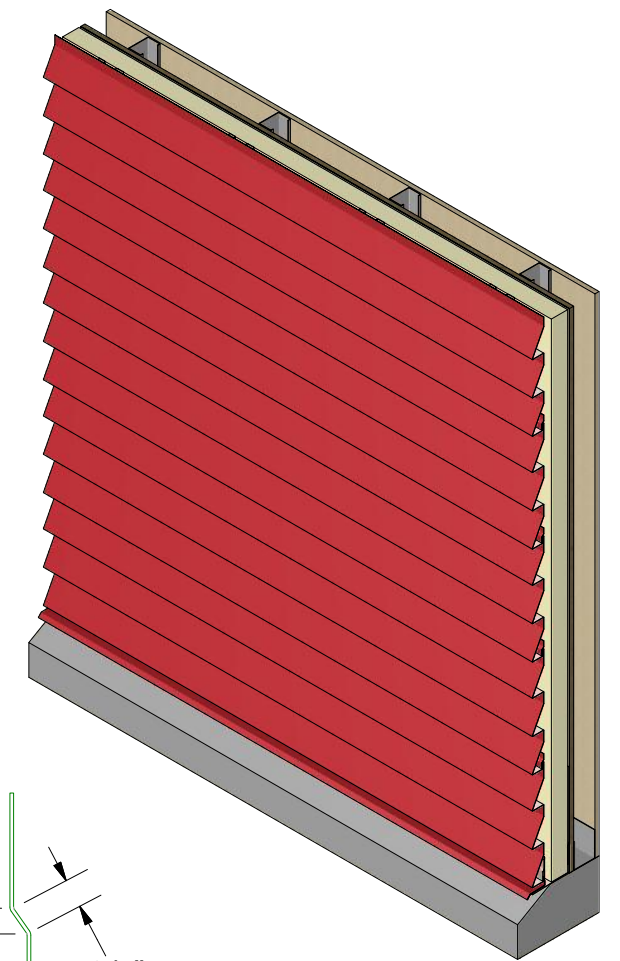
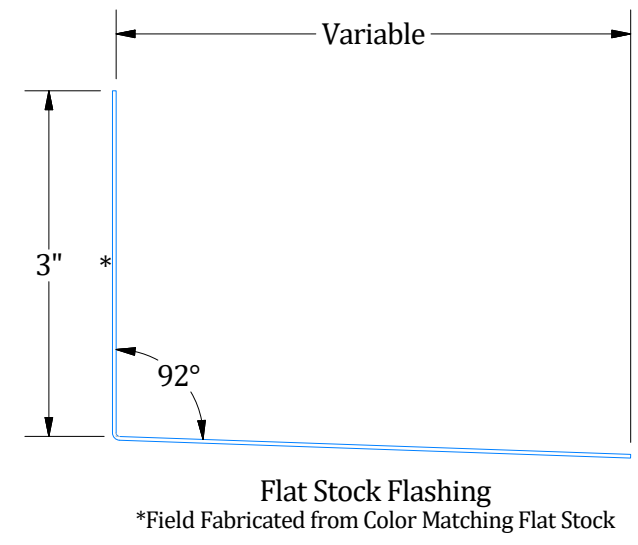
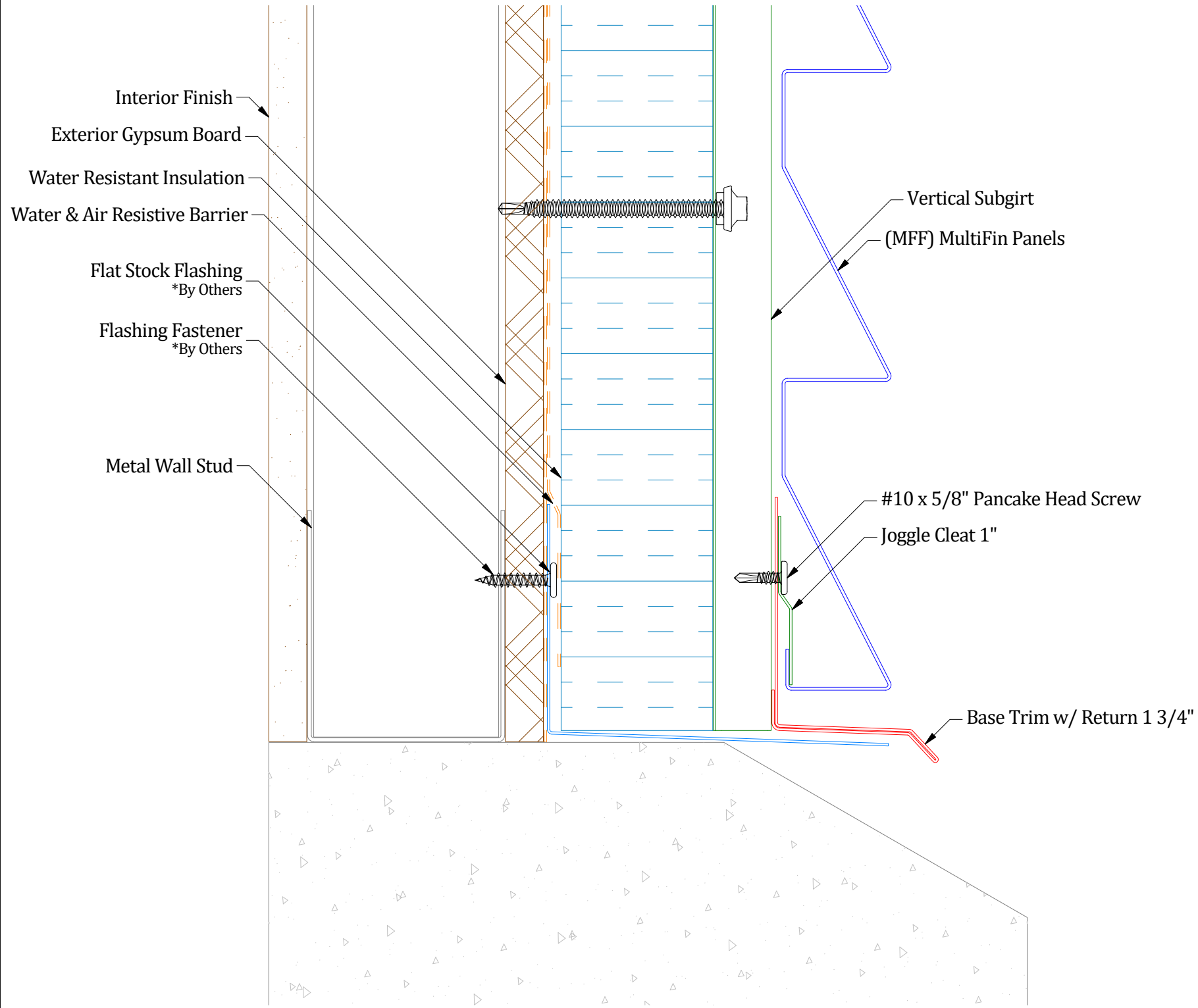

**Notes:**  
1) \* denotes color side.

**ATAS International, Inc.**  
Sustainable Solutions For A Better Future  
www.atas.com | info@atas.com  
800.468.1441

REV. NO.	DATE	DESCRIPTION OF REVISION	BY	APP	DWG TITLE:	DWG No:	DWG DATE:
0	5/1/2026	Initial Release	M.L.P.	D.S.	Open Framing Base Detail		5/1/2026
					PANELS/PRODUCT:		
					(MFF) MultiFin		
					APP BY:	D.S.	APP DATE:
							5/1/2026
					SHEET SIZE:	B	SCALE:
							X : X

# Horizontal Panel

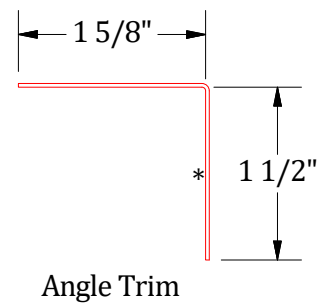
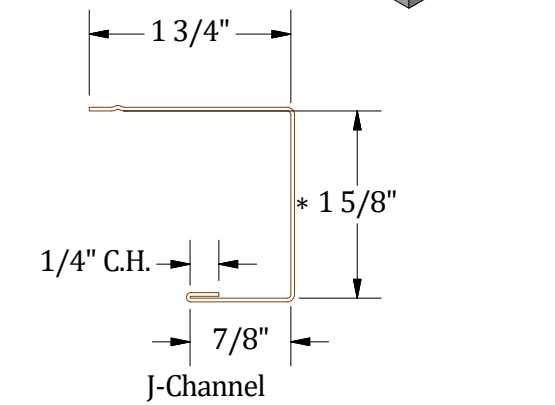
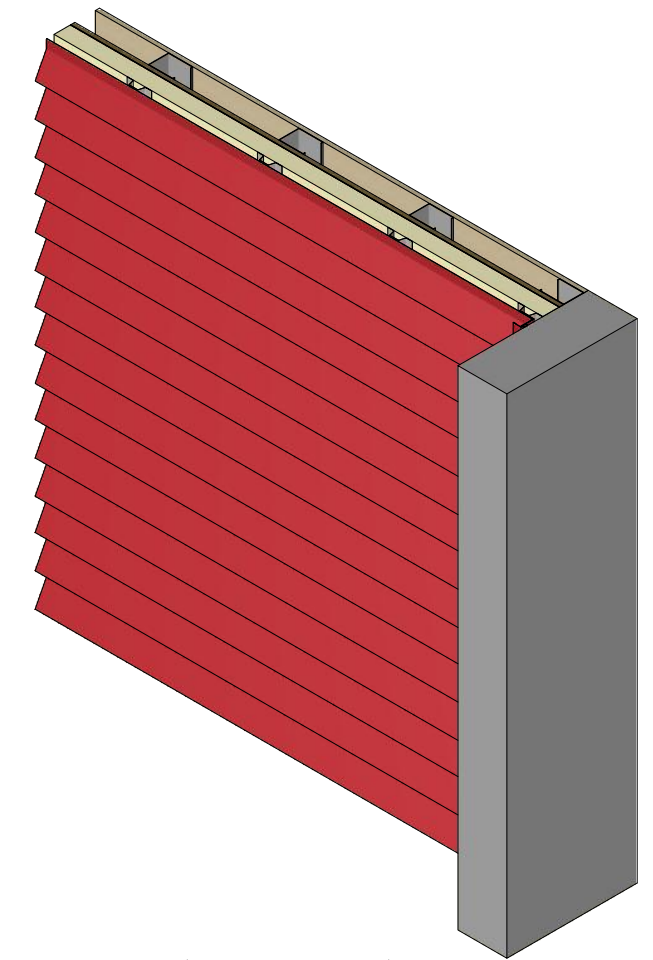
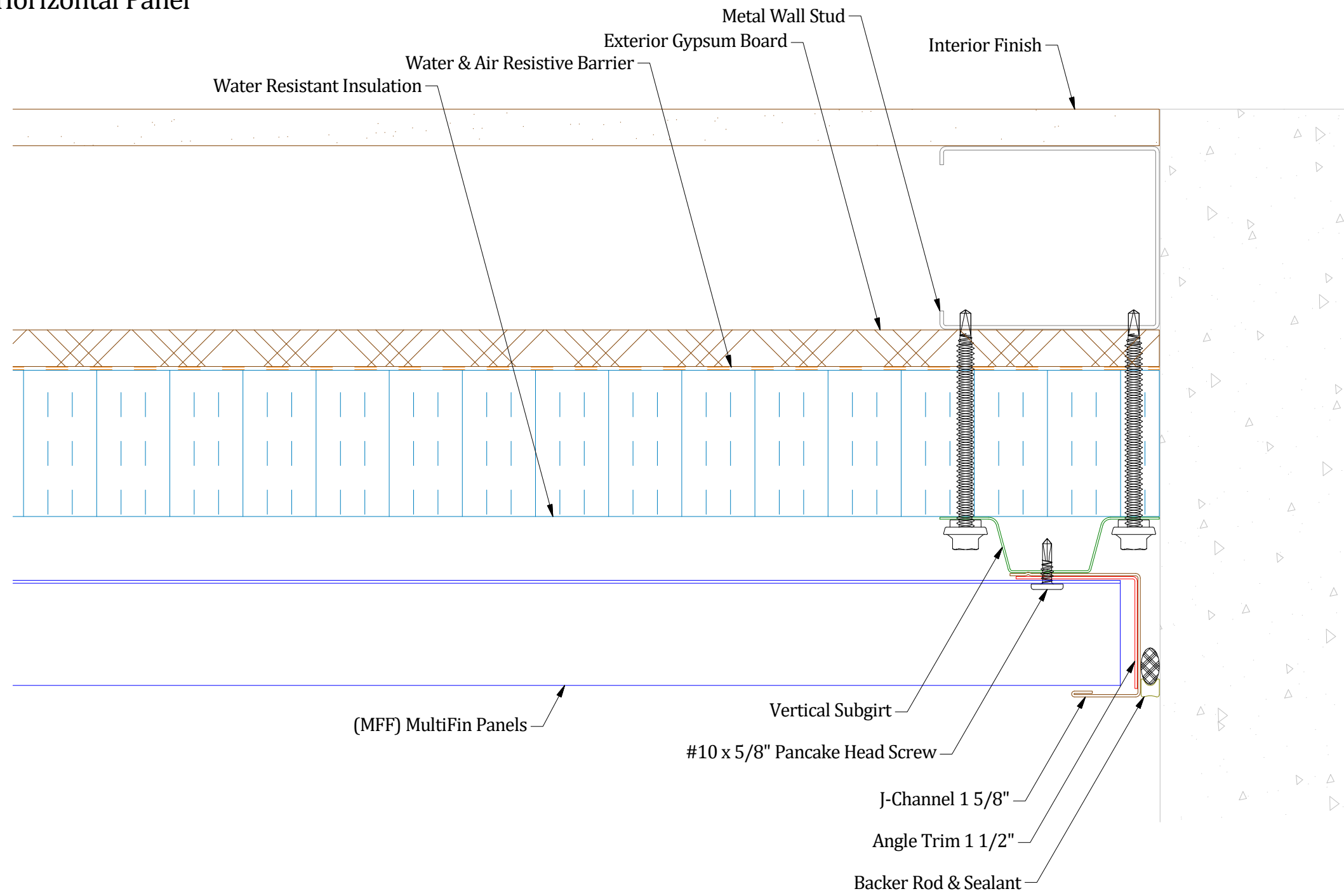

**Notes:**  
1) \* denotes color side.

**ATAS International, Inc.**  
Sustainable Solutions For A Better Future  
www.atas.com | info@atas.com  
800.468.1441

DWG TITLE: <b>Open Framing Endwall Detail</b>		DWG No.:		DWG BY: M.L.P.	DWG DATE: 5/1/2026
REV. NO.:		DATE:	DESCRIPTION OF REVISION:	BY:	APP:
0	5/1/2026	Initial Release		M.L.P.	D.S.
PANELS/PRODUCT: <b>(MFF) MultiFin</b>				APP BY: D.S.	APP DATE: 5/1/2026
				SHEET SIZE: B	SCALE: X : X

# Horizontal Panel

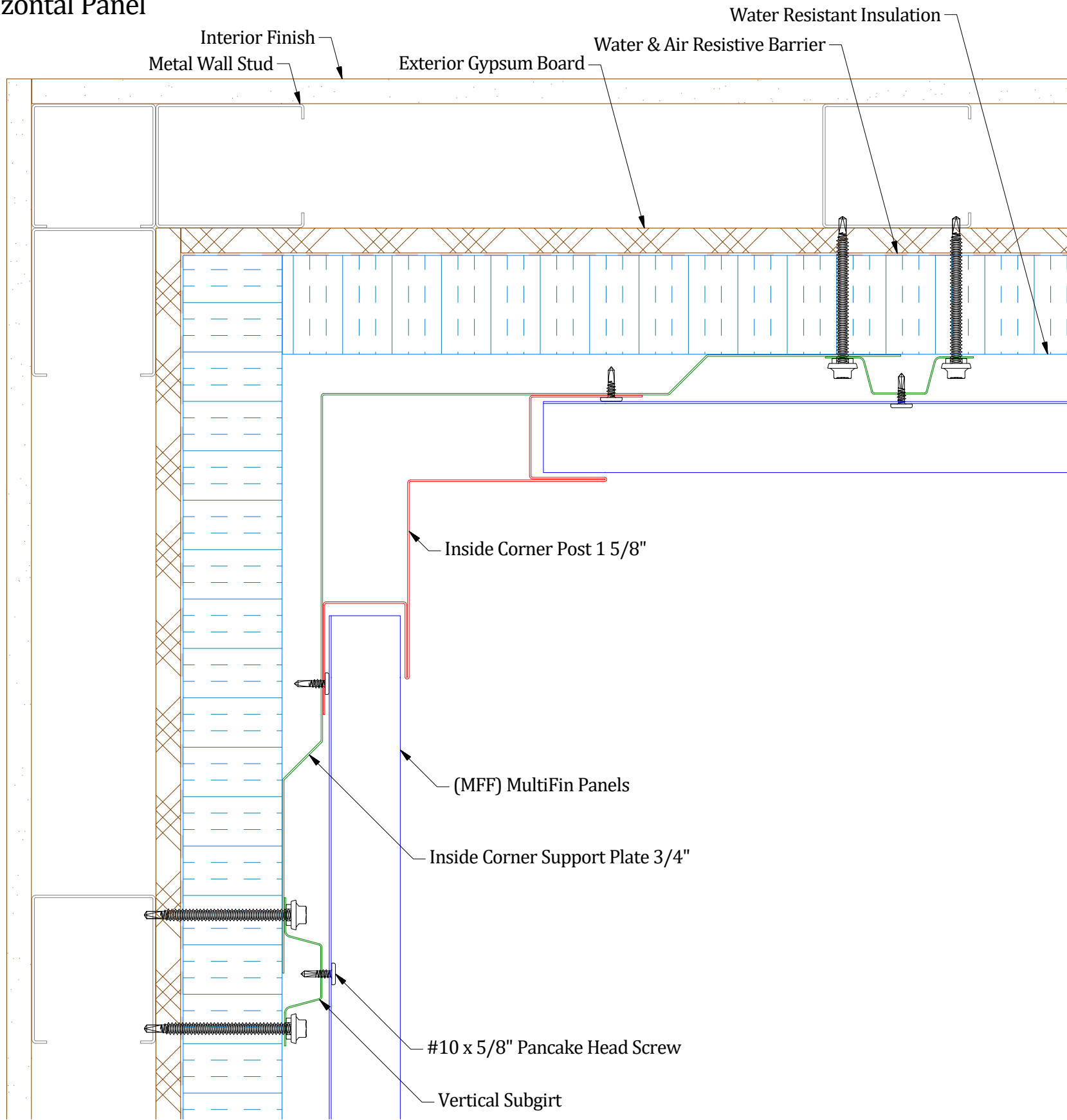

## Notes:

1) \* denotes color side.

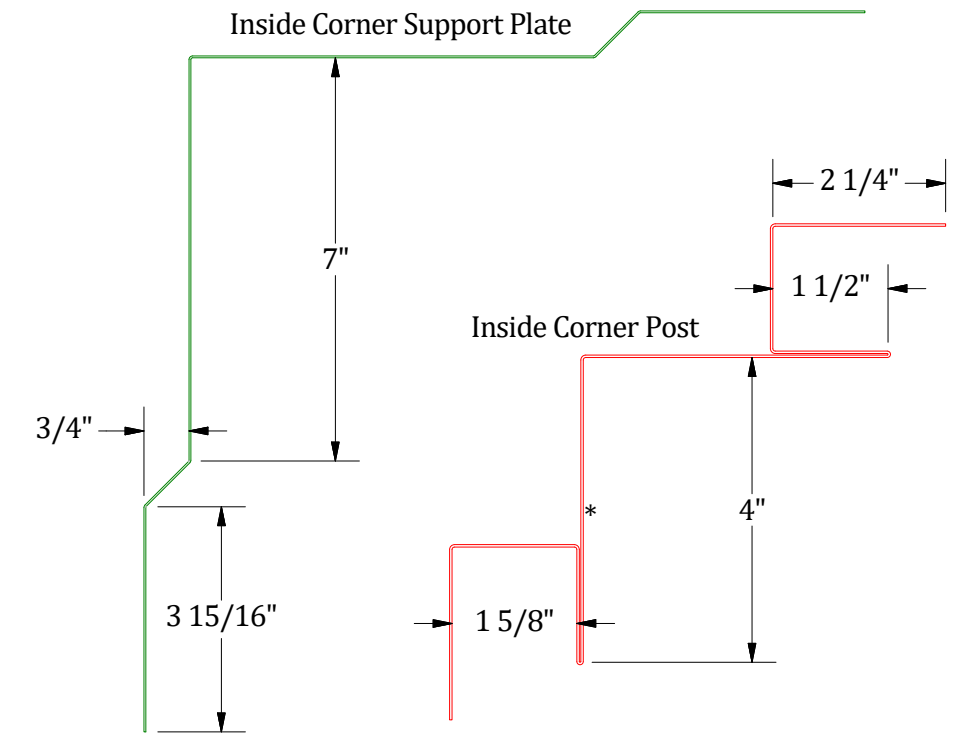
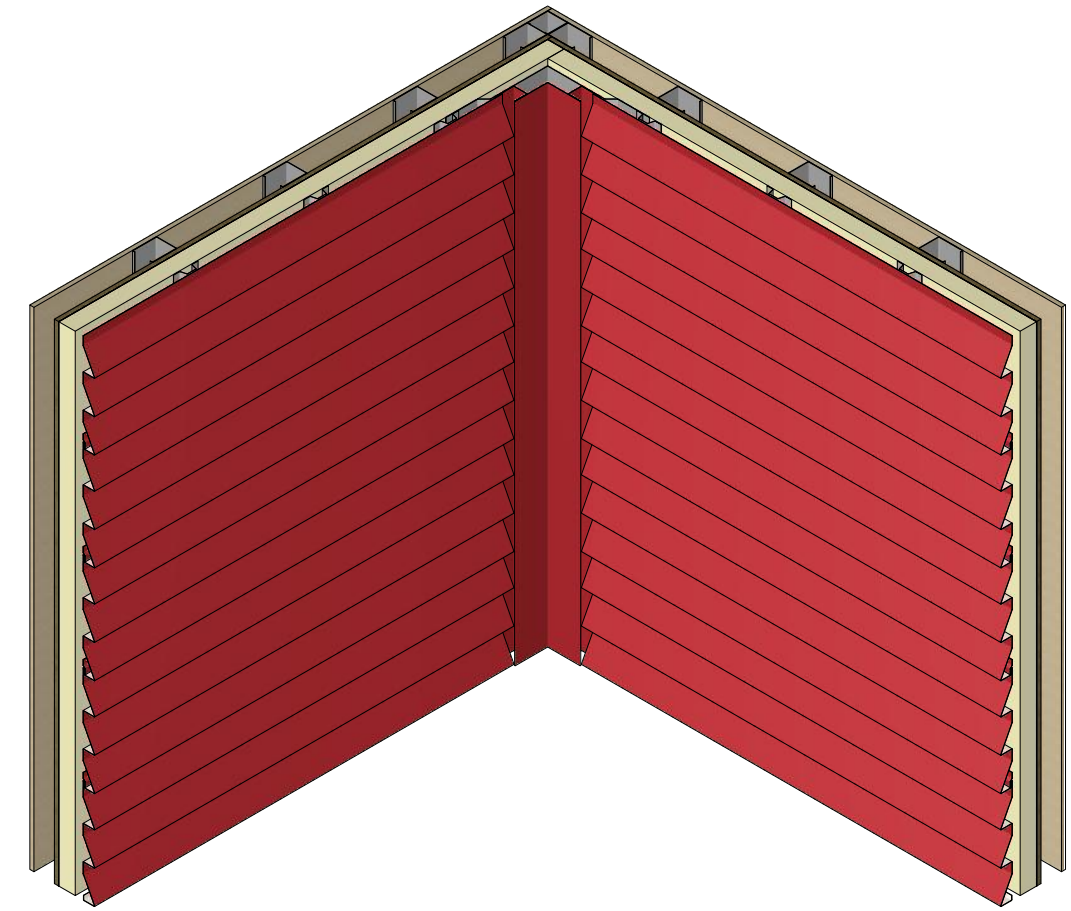

**ATAS International, Inc.**  
 Sustainable Solutions For A Better Future  
 www.atas.com | info@atas.com  
 800.468.1441

REV. NO.	DATE	DESCRIPTION OF REVISION	BY	APP	DWG. No.	DWG. DATE	APP. BY	APP. DATE	SHEET SIZE	SCALE
0	5/1/2026	Initial Release	M.L.P.	D.S.		5/1/2026		5/1/2026	B	X : X
					DWG. TITLE:		PANELS/PRODUCT:			
					Open Framing Inside Corner Post Detail		(MFF) MultiFin			

# Horizontal Panel

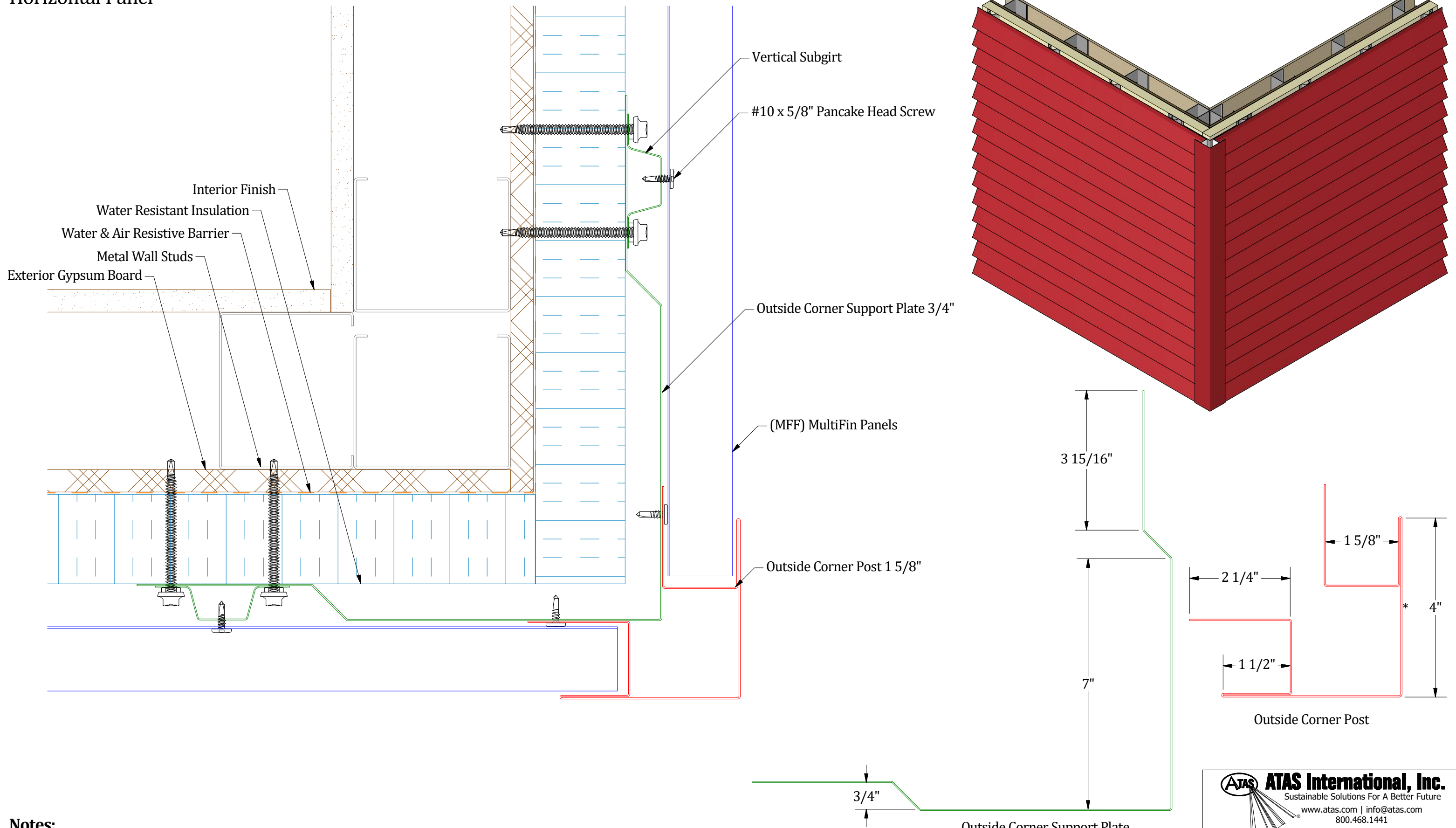

**Notes:**  
 1) \* denotes color side.

**ATAS International, Inc.**  
 Sustainable Solutions For A Better Future  
 www.atas.com | info@atas.com  
 800.468.1441

REV. NO.		DATE	DESCRIPTION OF REVISION	BY	APP	DWG TITLE:	
0	5/1/2026	Initial Release		M.L.P.	D.S.	Open Framing Outside Corner Post Detail	
DWG No.						DWG DATE:	5/1/2026
APP BY:						D.S.	APP DATE:
PANELS/PRODUCT:						(MFF) MultiFin	SHEET SIZE:
						B	SCALE:
						X	X

# Horizontal Panel

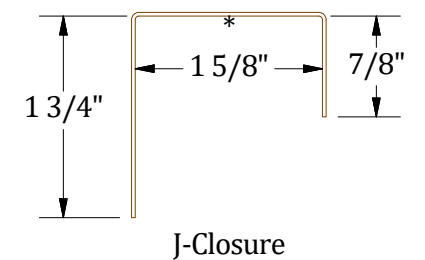
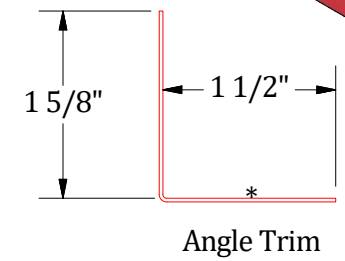
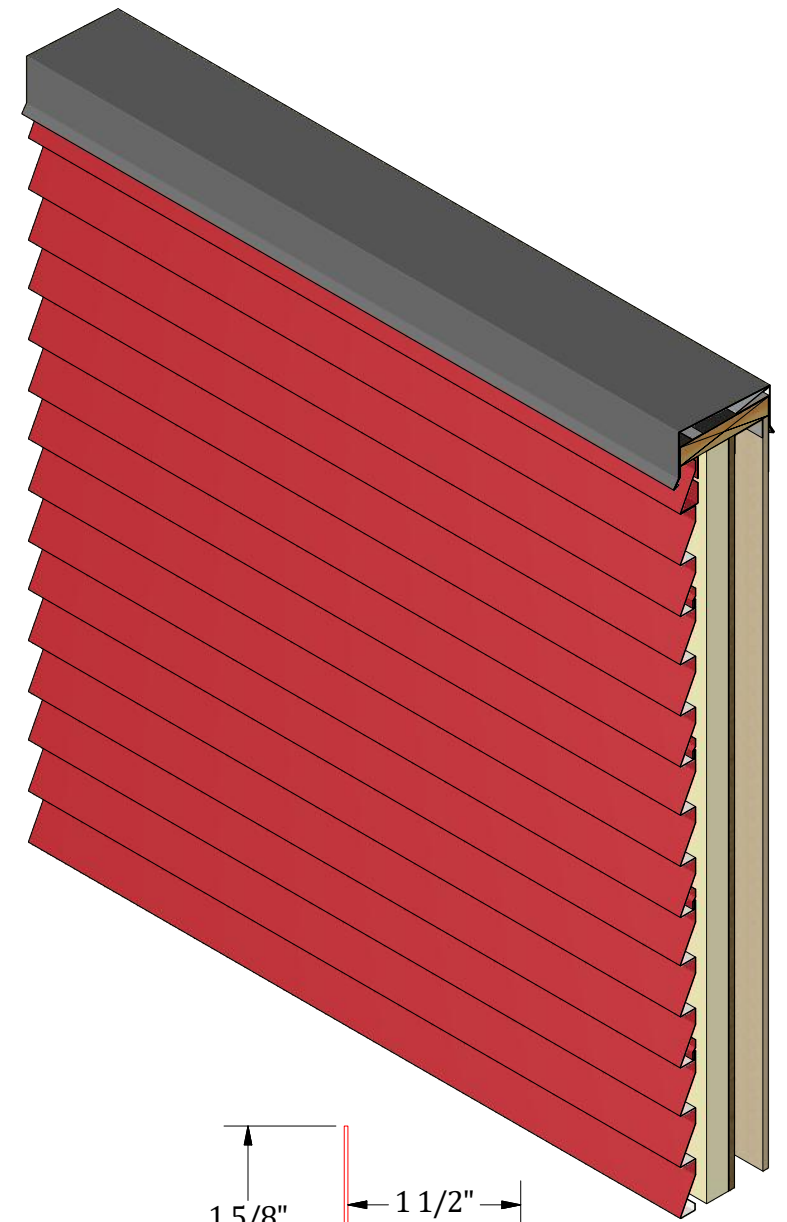
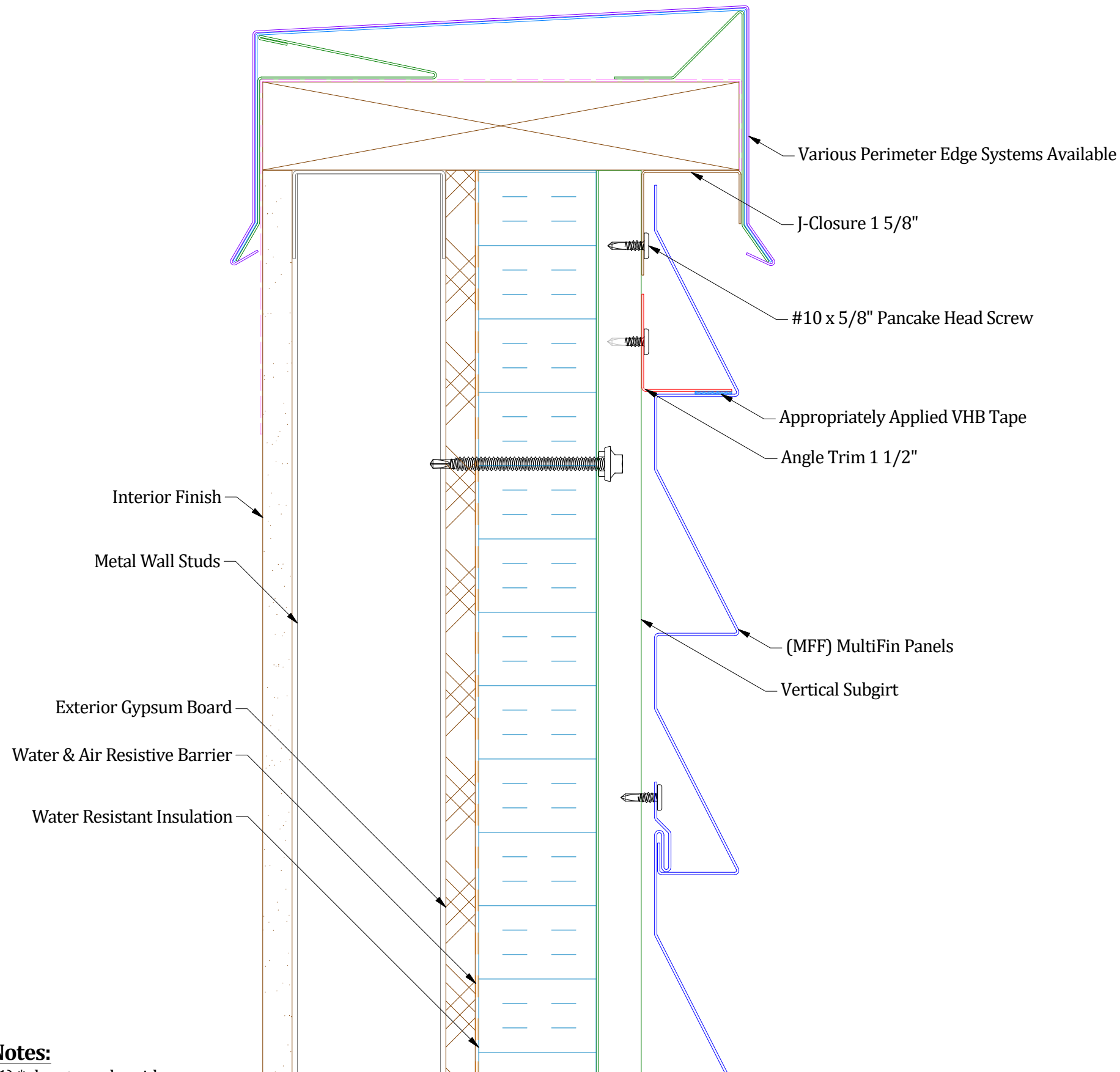

**Notes:**  
1) \* denotes color side.

**ATAS** **ATAS International, Inc.**  
Sustainable Solutions For A Better Future  
www.atas.com | info@atas.com  
800.468.1441

DWG TITLE: <b>Open Framing Top of Wall Detail</b>		DWG No.:		DWG BY: M.L.P.	DWG DATE: 5/1/2026
0	5/1/2026	Initial Release	M.L.P.	D.S.	APP DATE: 5/1/2026
REV. NO.	DATE	DESCRIPTION OF REVISION	BY	APP	PANELS/PRODUCT: <b>(MFF) MultiFin</b>
					SHEET SIZE: B
					SCALE: X : X

# Horizontal Panel

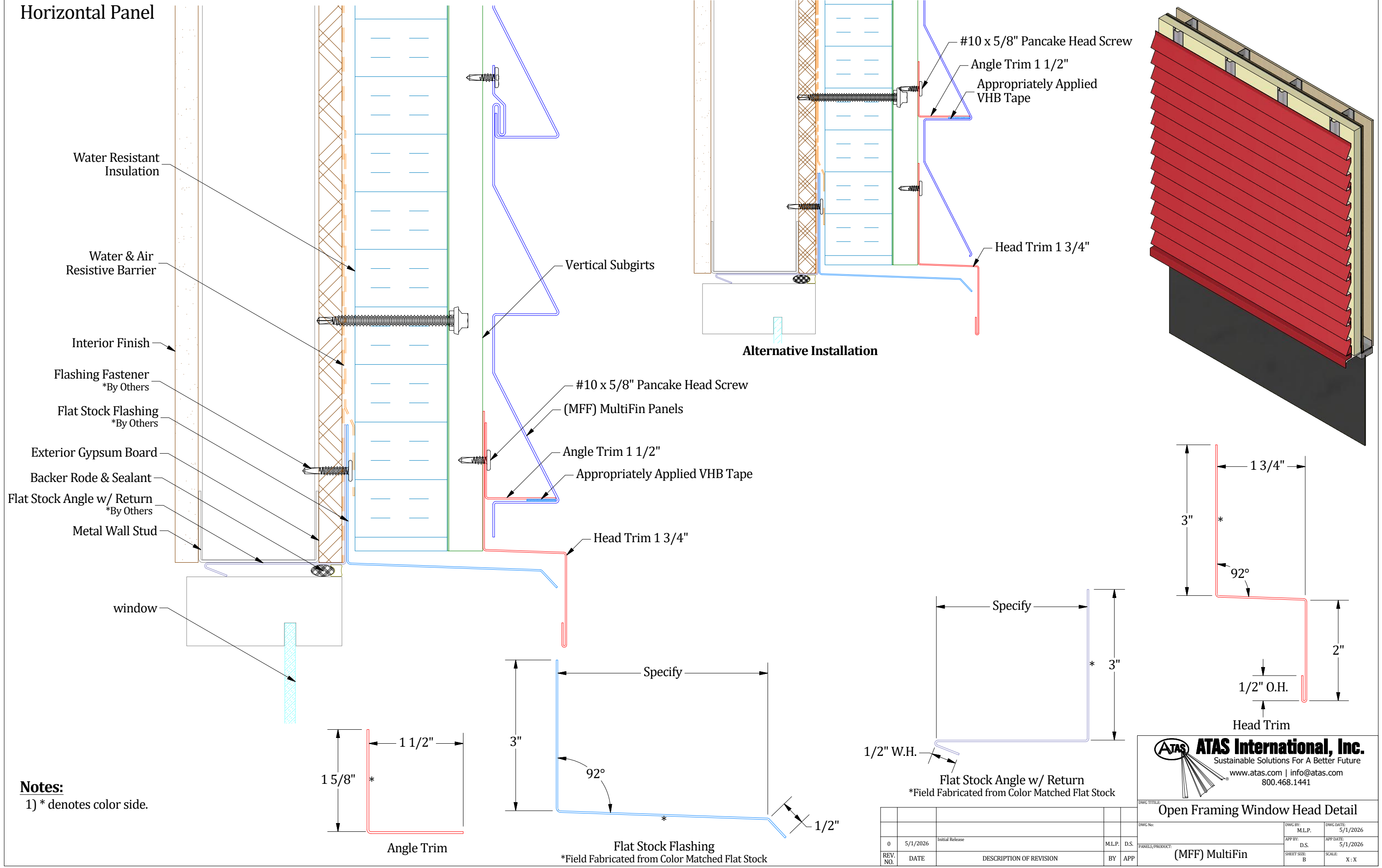

**Notes:**  
1) \* denotes color side.

**ATAS International, Inc.**  
Sustainable Solutions For A Better Future  
www.atas.com | info@atas.com  
800.468.1441

DWG TITLE: **Open Framing Window Head Detail**

DWG No:	M.L.P.	DWG DATE:	5/1/2026
APP BY:	D.S.	APP DATE:	5/1/2026
PANELS/PRODUCT:	<b>(MFF) MultiFin</b>		
SHEET SIZE:	B	SCALE:	X : X

REV. NO.	DATE	DESCRIPTION OF REVISION	BY	APP
0	5/1/2026	Initial Release	M.L.P.	D.S.

# Horizontal Panel

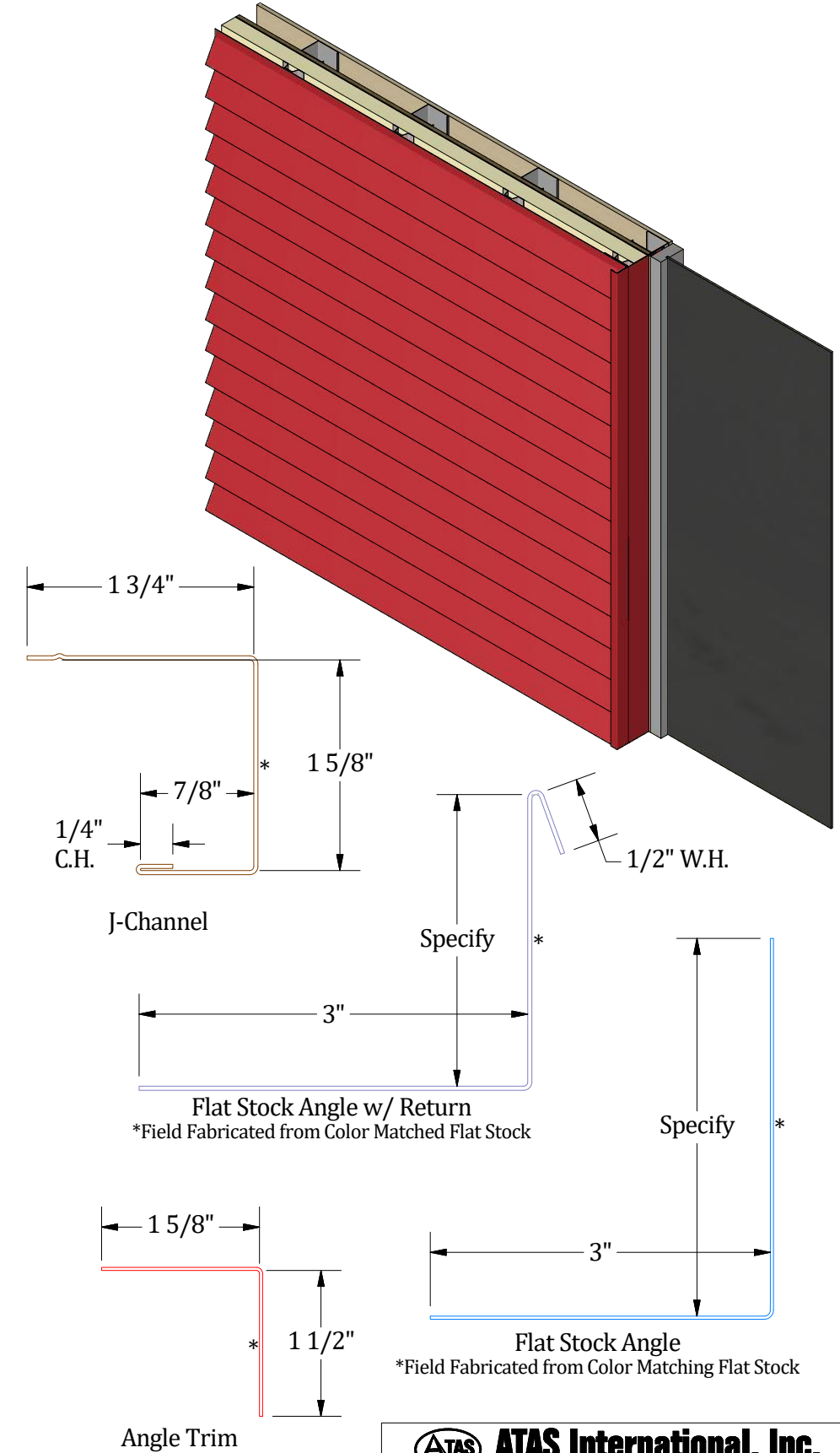
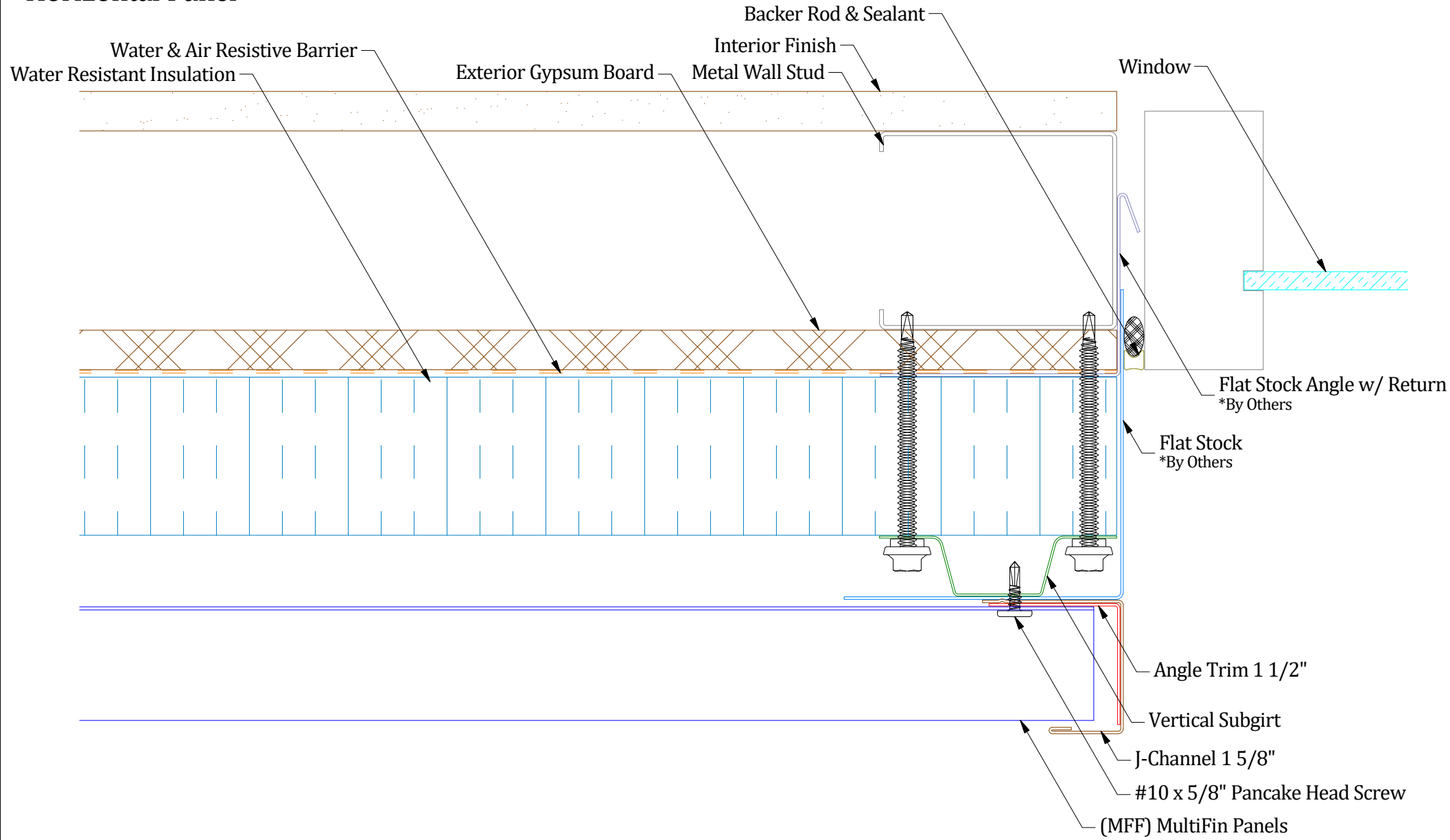

## Notes:

1) \* denotes color side.

**ATAS International, Inc.**  
 Sustainable Solutions For A Better Future  
 www.atas.com | info@atas.com  
 800.468.1441

REV. NO.		DATE	DESCRIPTION OF REVISION	BY	APP	DWG TITLE: <b>Open Framing Window Jamb Detail</b>	
0	5/1/2026	Initial Release		M.L.P.	D.S.	DWG No.:	
						DWG DATE: 5/1/2026	
						DWG BY: M.L.P.	
						APP BY: D.S.	
						APP DATE: 5/1/2026	
						DWG TITLE: (MFF) MultiFin	
						SHEET SIZE: B	
						SCALE: X : X	

# Horizontal Panel

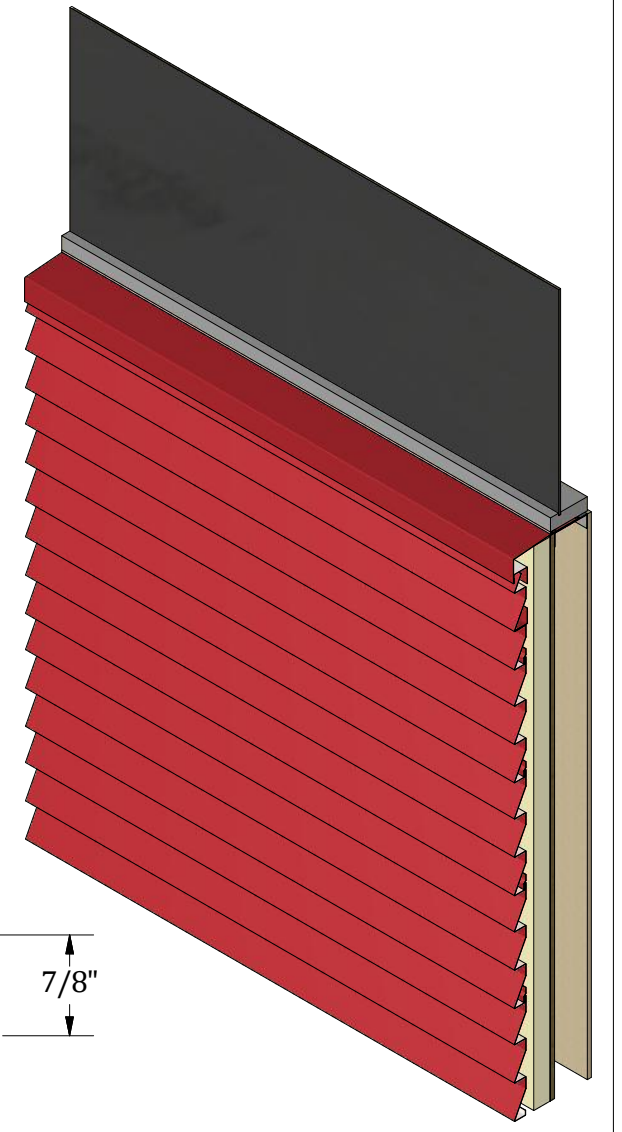
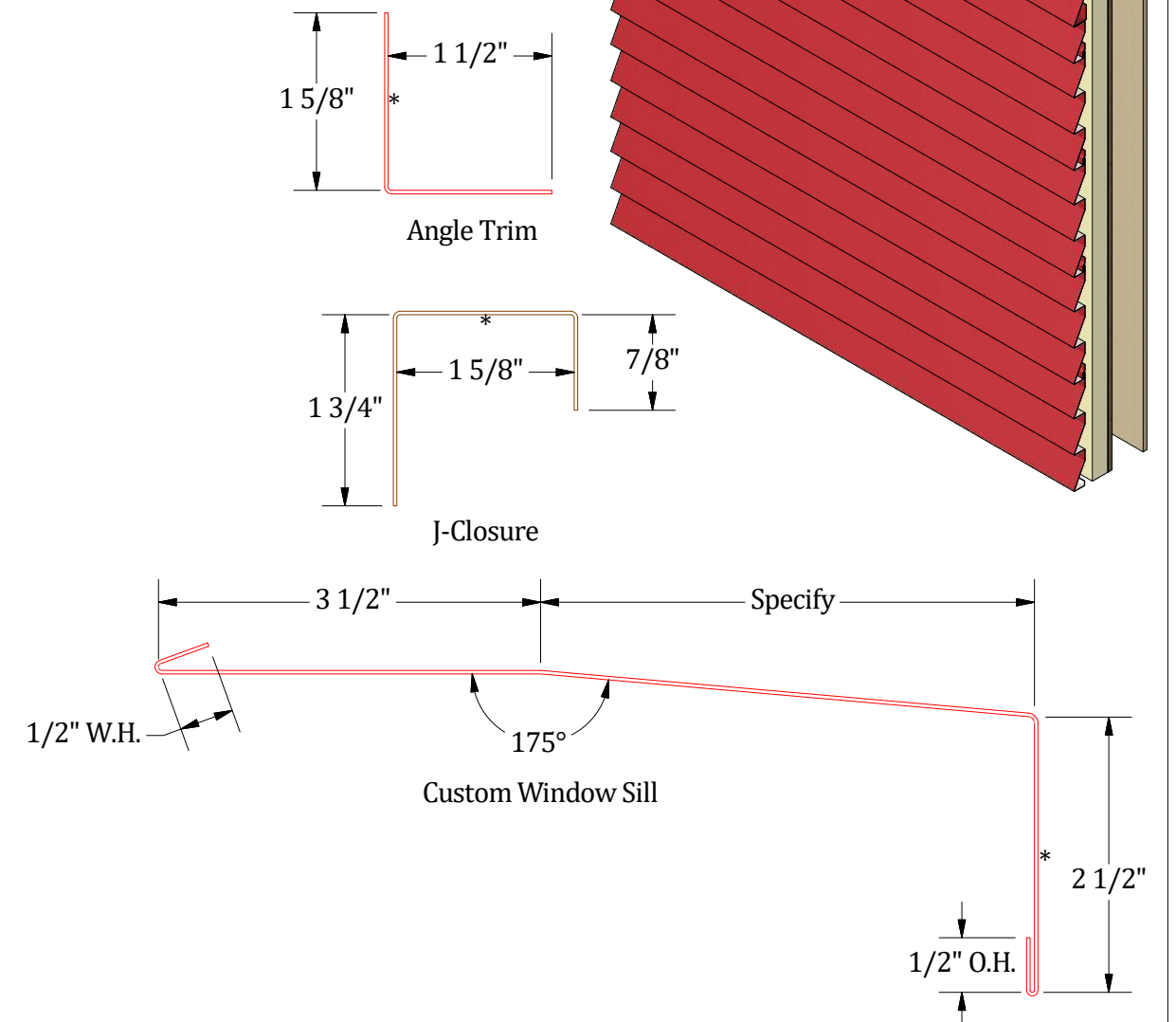
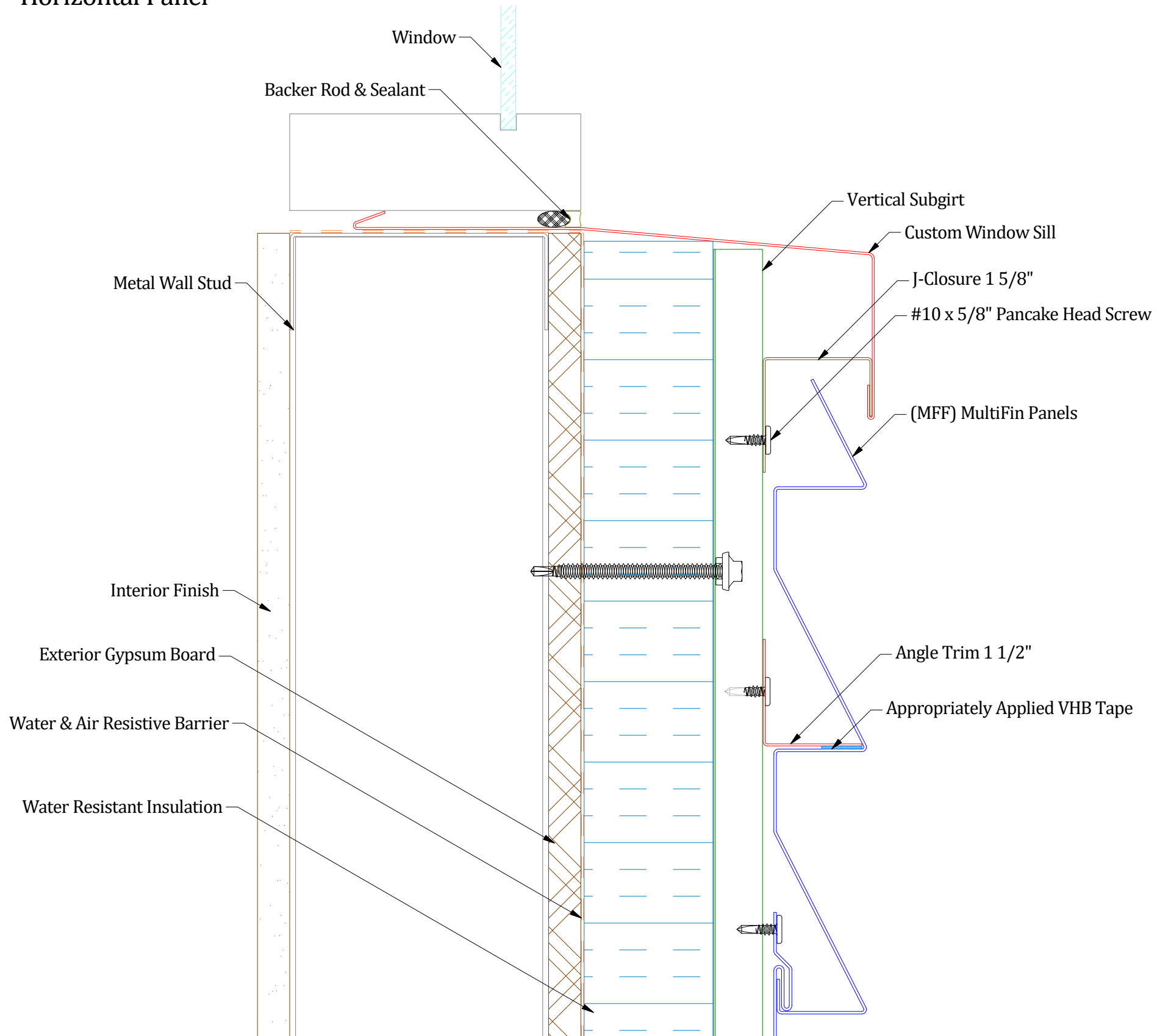

## Notes:

1) \* denotes color side.

**ATAS International, Inc.**  
 Sustainable Solutions For A Better Future  
 www.atas.com | info@atas.com  
 800.468.1441

REV. NO.		DATE	DESCRIPTION OF REVISION	BY	APP	DWG TITLE: <b>Open Framing Window Sill Detail</b>	
0	5/1/2026	Initial Release		M.L.P.	D.S.	DWG No.:	
						DWG DATE: 5/1/2026	
						APP BY: D.S.	
						APP DATE: 5/1/2026	
						SHEET SIZE: B	
						SCALE: X : X	