

MFF120

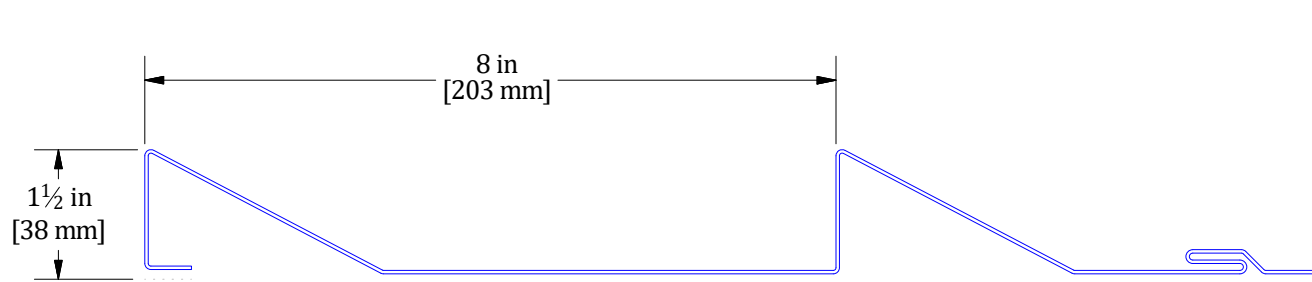

MFF121

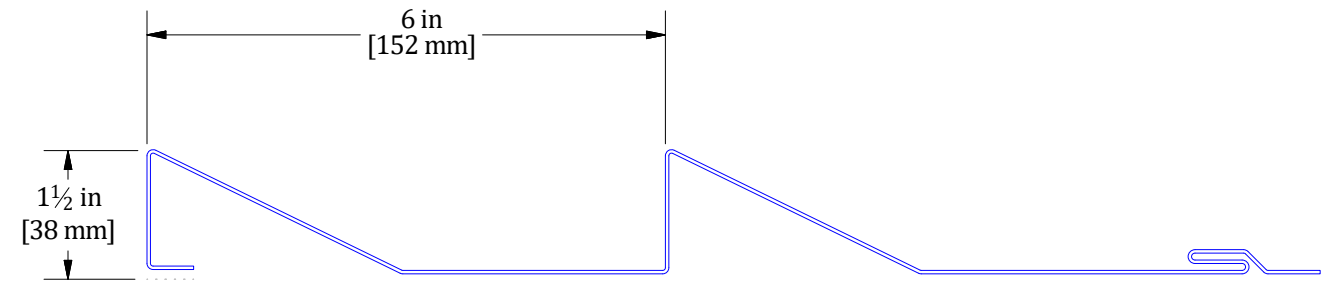

MFF123

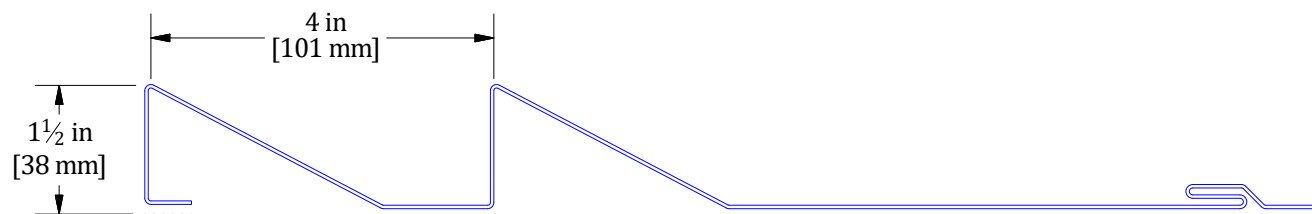

MFF122



MFF124

Notes:



DWG TITLE:		Panel Profiles	
DWG No:		DWG BY:	M.L.P.
		DWG DATE:	4/30/2026
APP BY:	D.S.	APP DATE:	4/30/2026
PANELS/PRODUCT:	(MFF) MultiFin	SHEET SIZE:	B
		SCALE:	X : X

REV. NO.	DATE	DESCRIPTION OF REVISION	BY	APP
0	4/30/2026	Initial Release	M.L.P.	D.S.

Secure Fastener in Center of the Slot
 Field Pre-Punch Fastener Slots to allow for Panel Expansion and Contraction

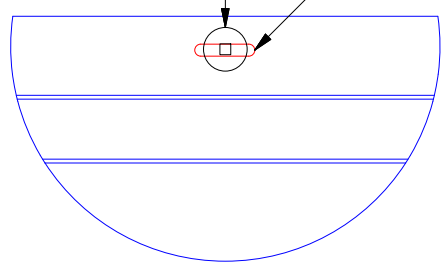

DETAIL A

Pin Panel in Center (x3)

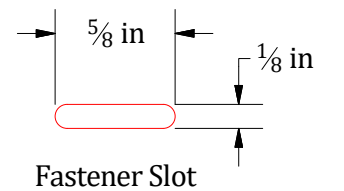
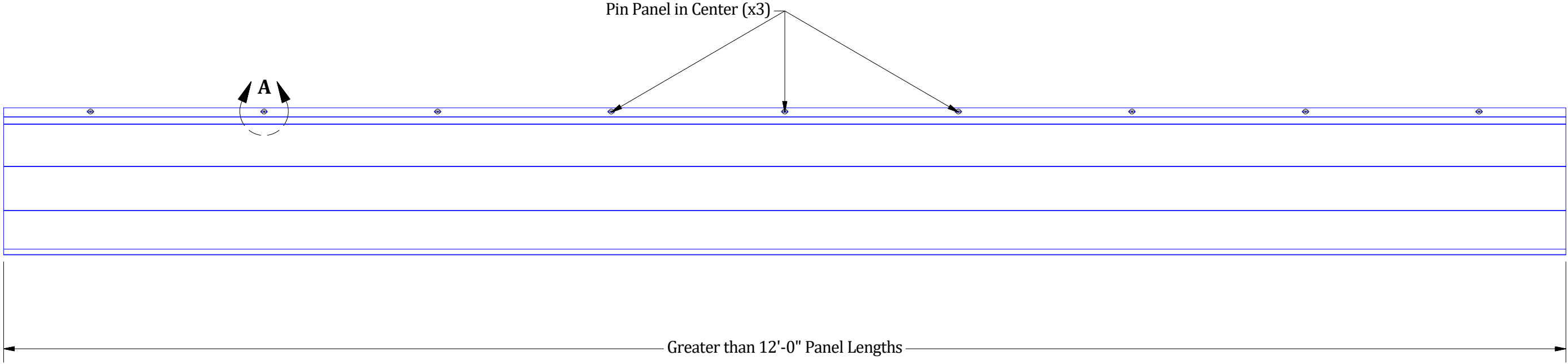

Notes:

ATAS **ATAS International, Inc.**
 Sustainable Solutions For A Better Future
 www.atas.com | info@atas.com
 800.468.1441

DWG TITLE: Panel Fastening Slot Detail		DWG No.:		DWG BY: M.L.P.	DWG DATE: 4/30/2026
REV. NO.:		DATE:		APP BY: D.S.	APP DATE: 4/30/2026
0		4/30/2026		PANELS/PRODUCT: (MFF) MultiFin	
DESCRIPTION OF REVISION: Initial Release		BY: M.L.P.	APP: D.S.	SHEET SIZE: B	SCALE: X : X

Horizontal Panel

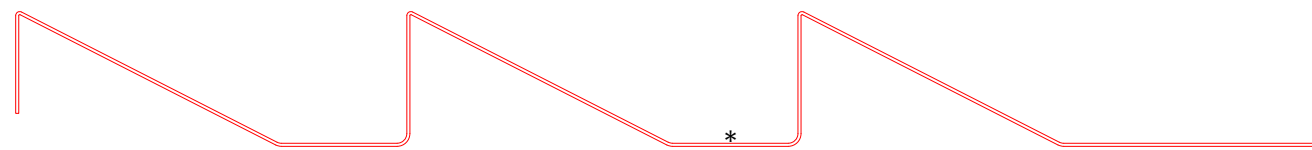
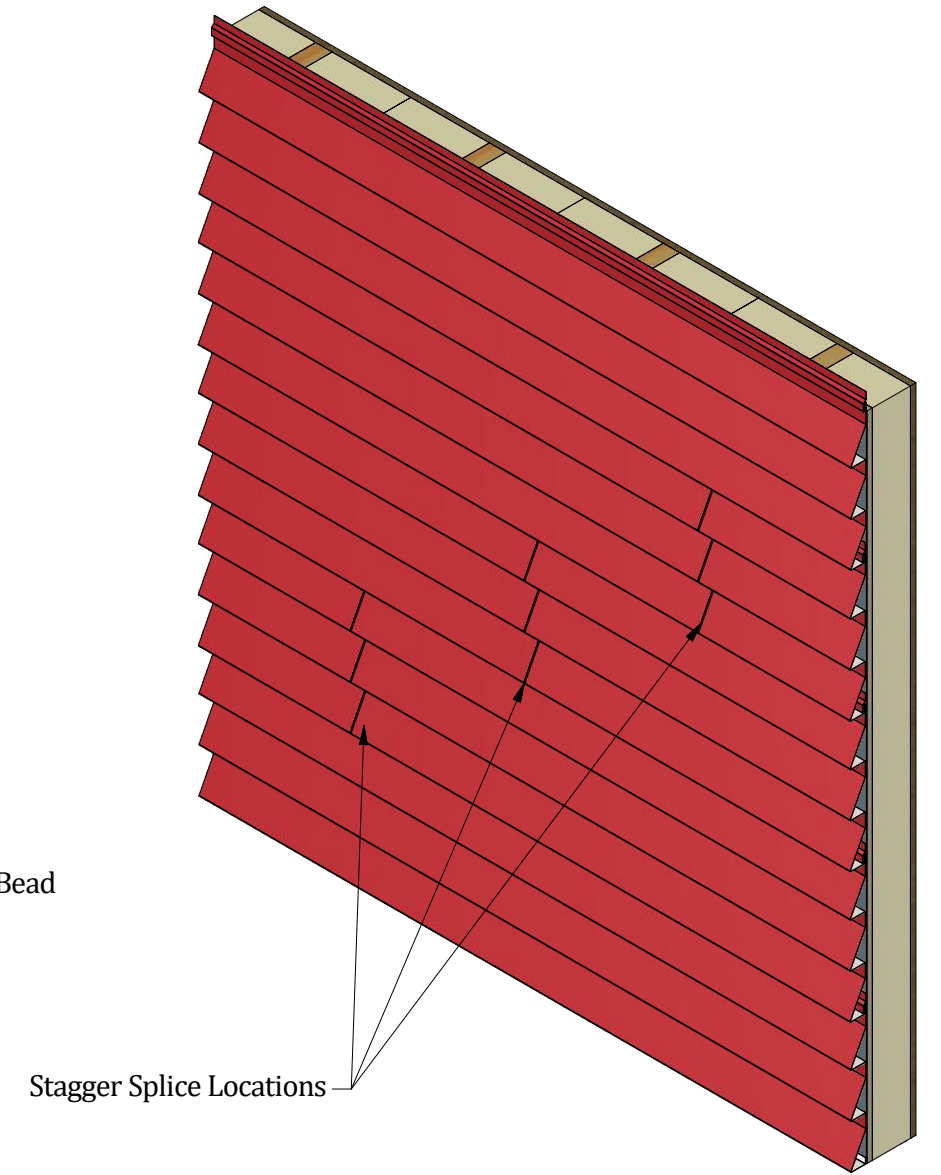
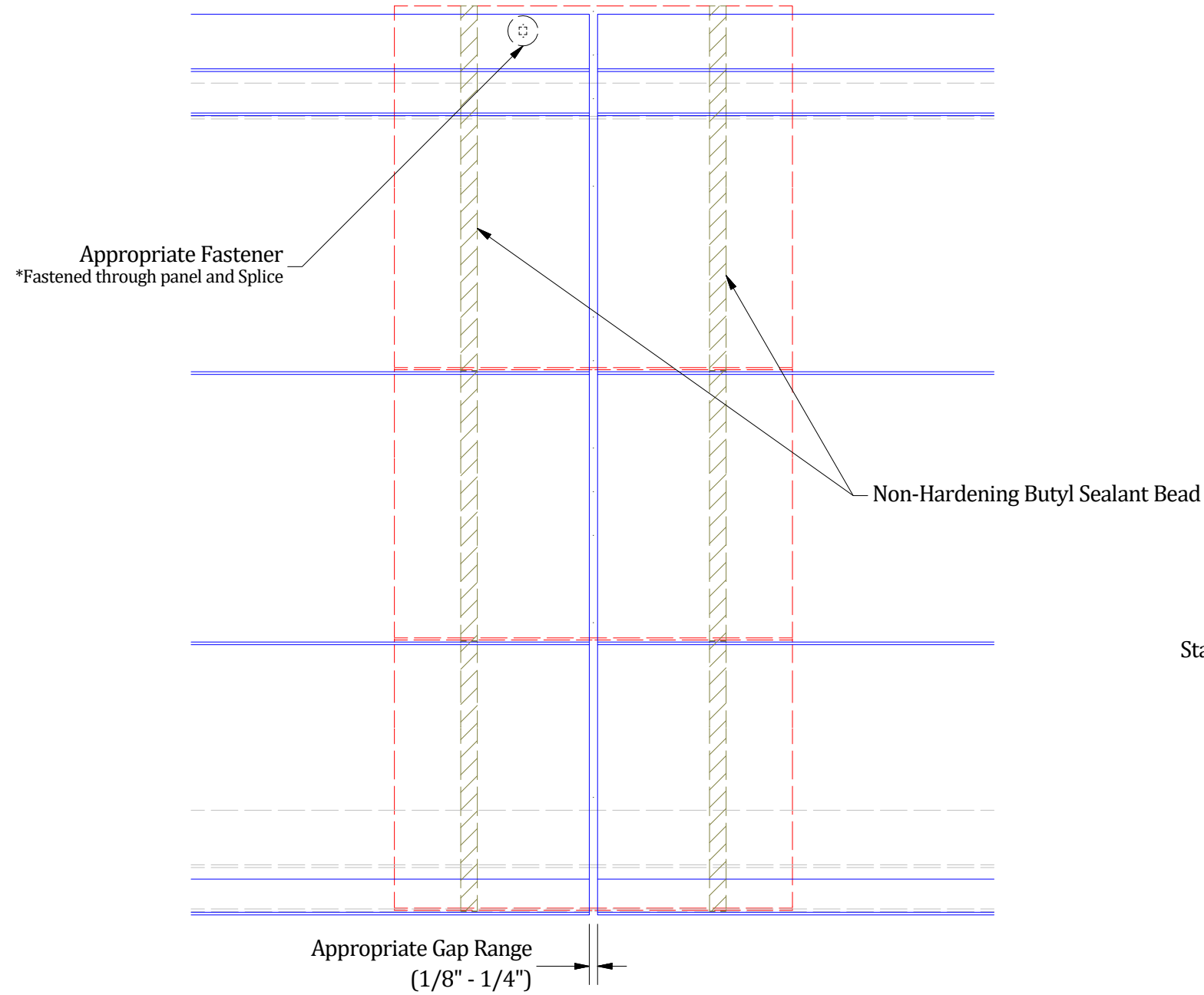
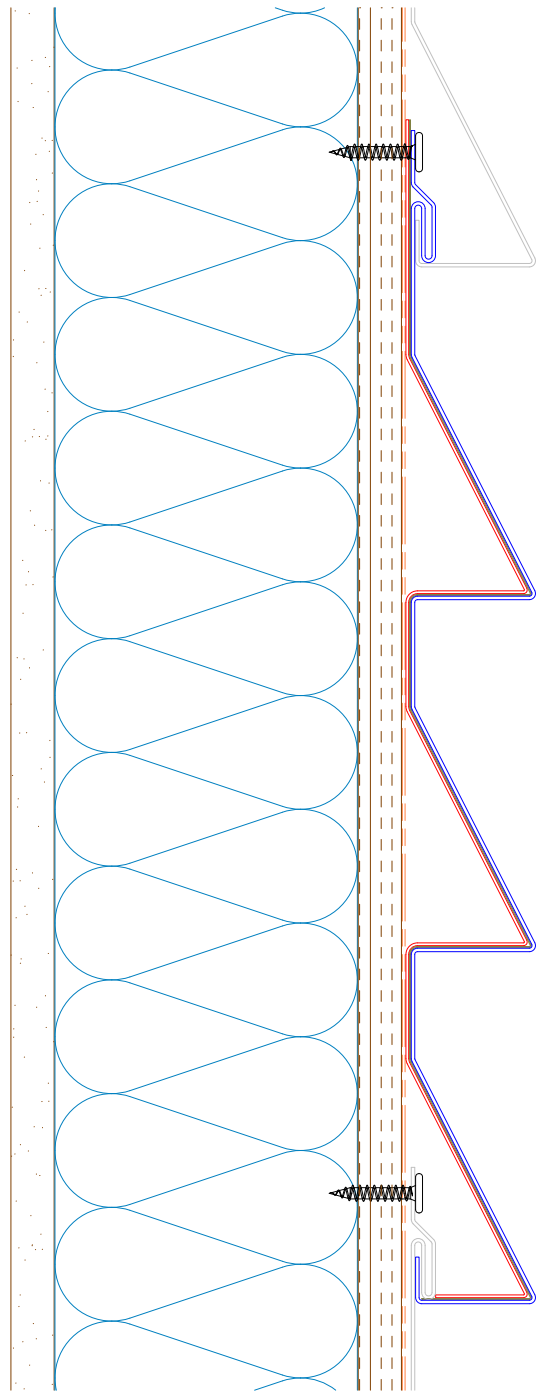

Notes:

- 1) * denotes color side.
- 2) Splice Profile varies on Panel Profile.



DWG TITLE: Splice Installation	
DWG No:	DWG DATE: 4/30/2026
APP BY: M.L.P.	APP DATE: 4/30/2026
BY: D.S.	SCALE: X : X
PANELS/PRODUCT: (MFF) MultiFin	

REV. NO.	DATE	DESCRIPTION OF REVISION	BY	APP
0	4/30/2026	Initial Release	M.L.P.	D.S.

Horizontal Panel

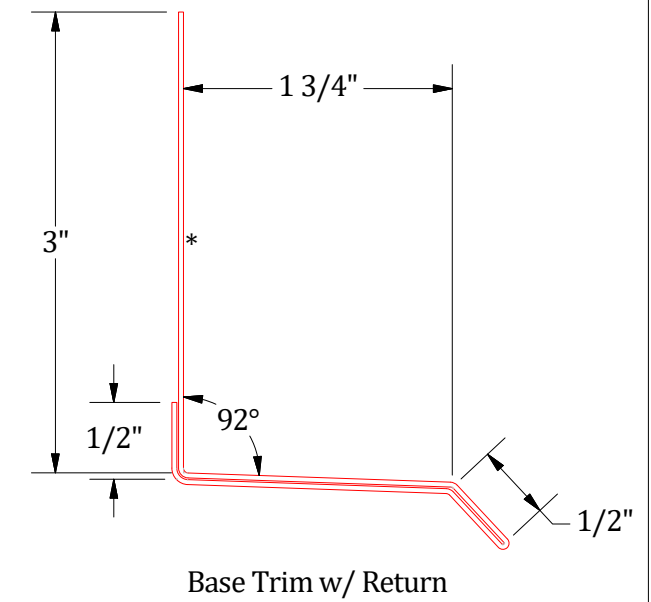
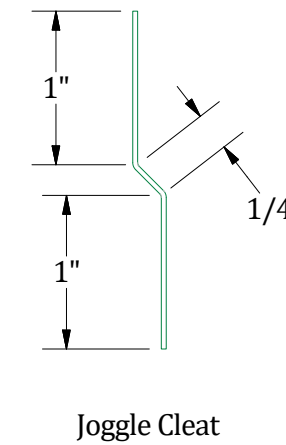
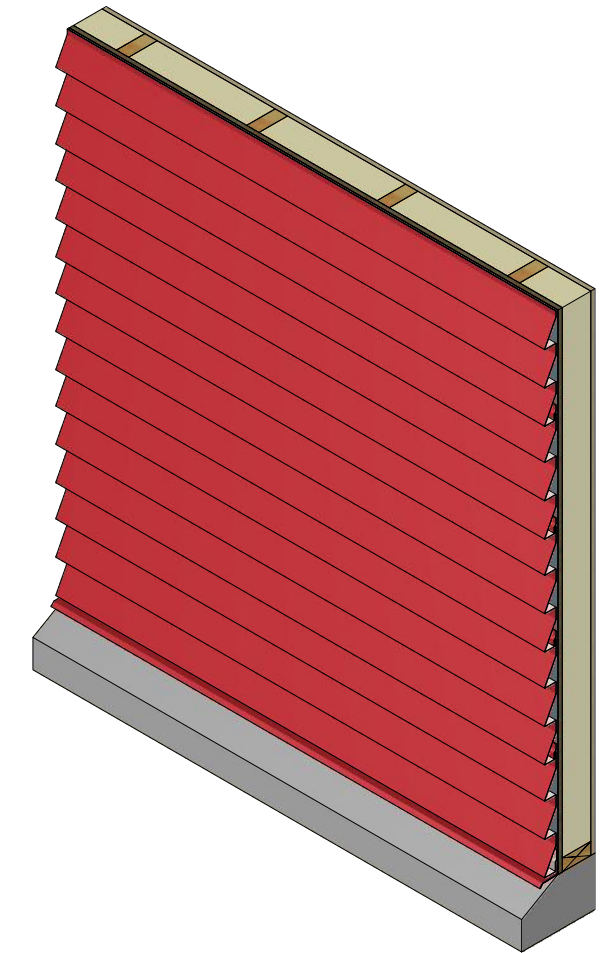
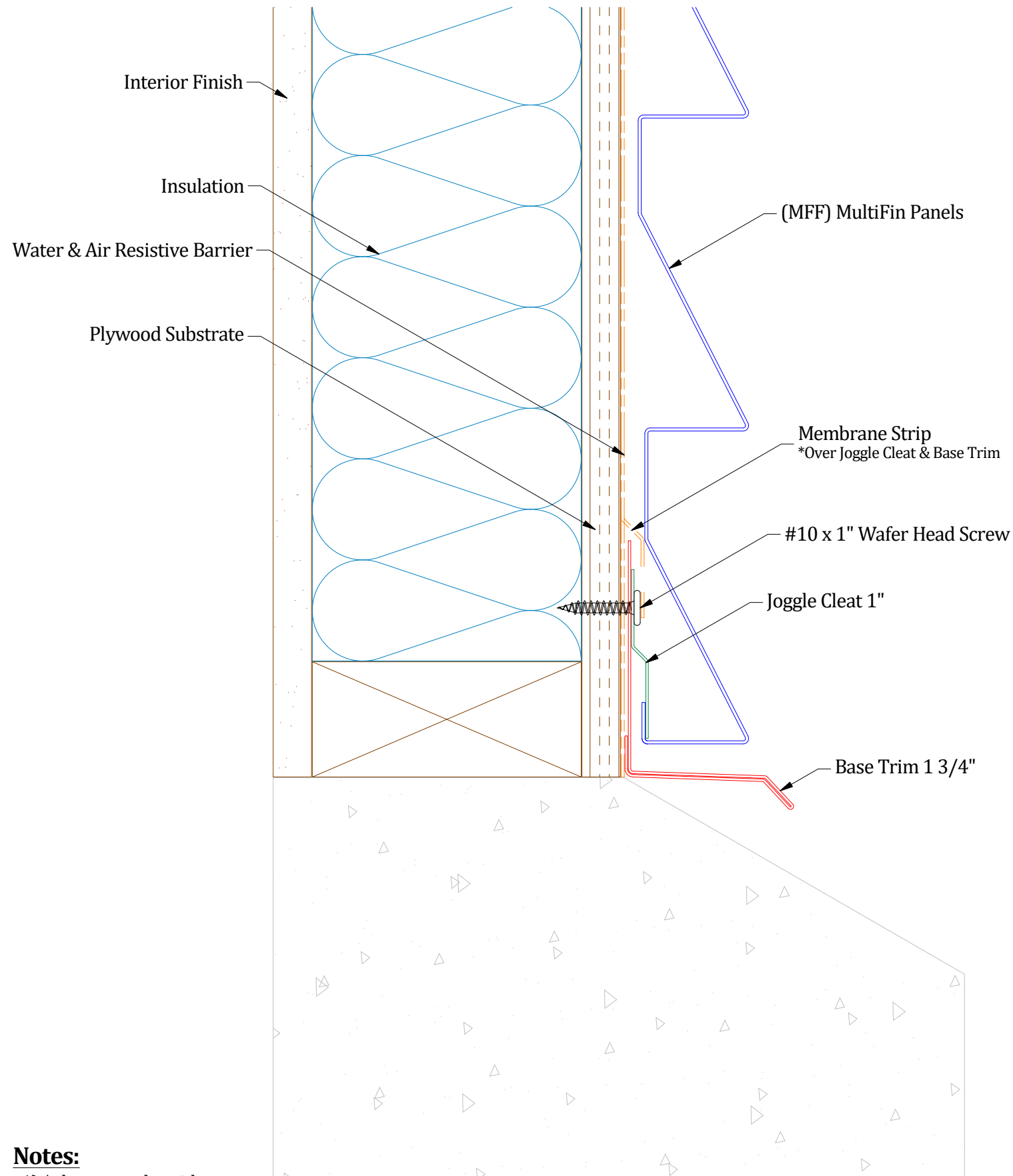

Notes:
1) * denotes color side.

ATAS International, Inc.
Sustainable Solutions For A Better Future
www.atas.com | info@atas.com
800.468.1441

REV. NO.	DATE	DESCRIPTION OF REVISION	BY	APP	PANELS/PRODUCT:	DWG No.	DWG DATE:	APP BY:	APP DATE:	SHEET SIZE:	SCALE:
0	4/30/2026	Initial Release	M.L.P.	D.S.	(MFF) MultiFin		4/30/2026	D.S.	4/30/2026	B	X : X

Horizontal Panel

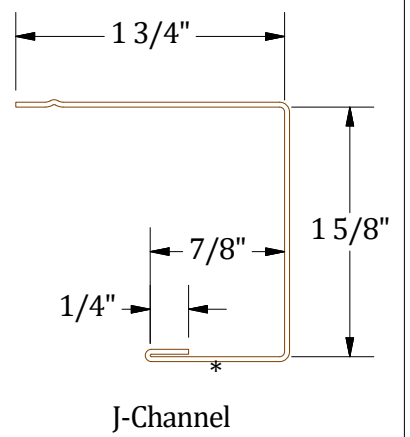
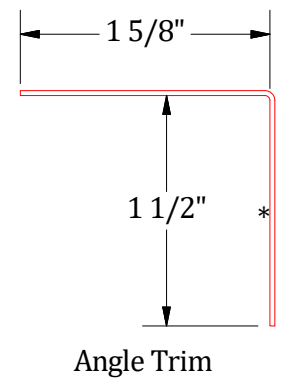
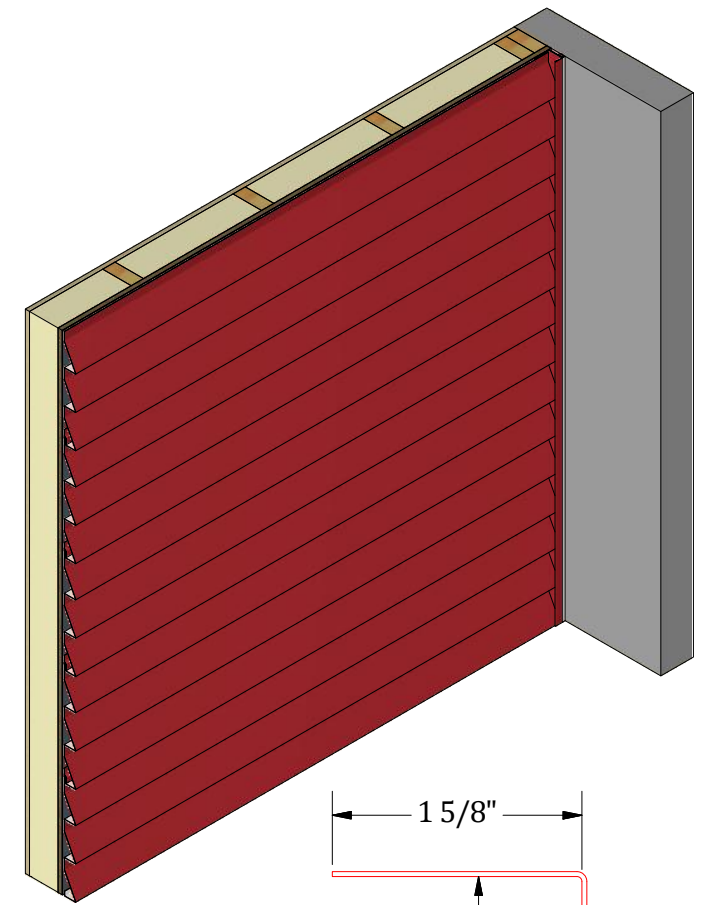
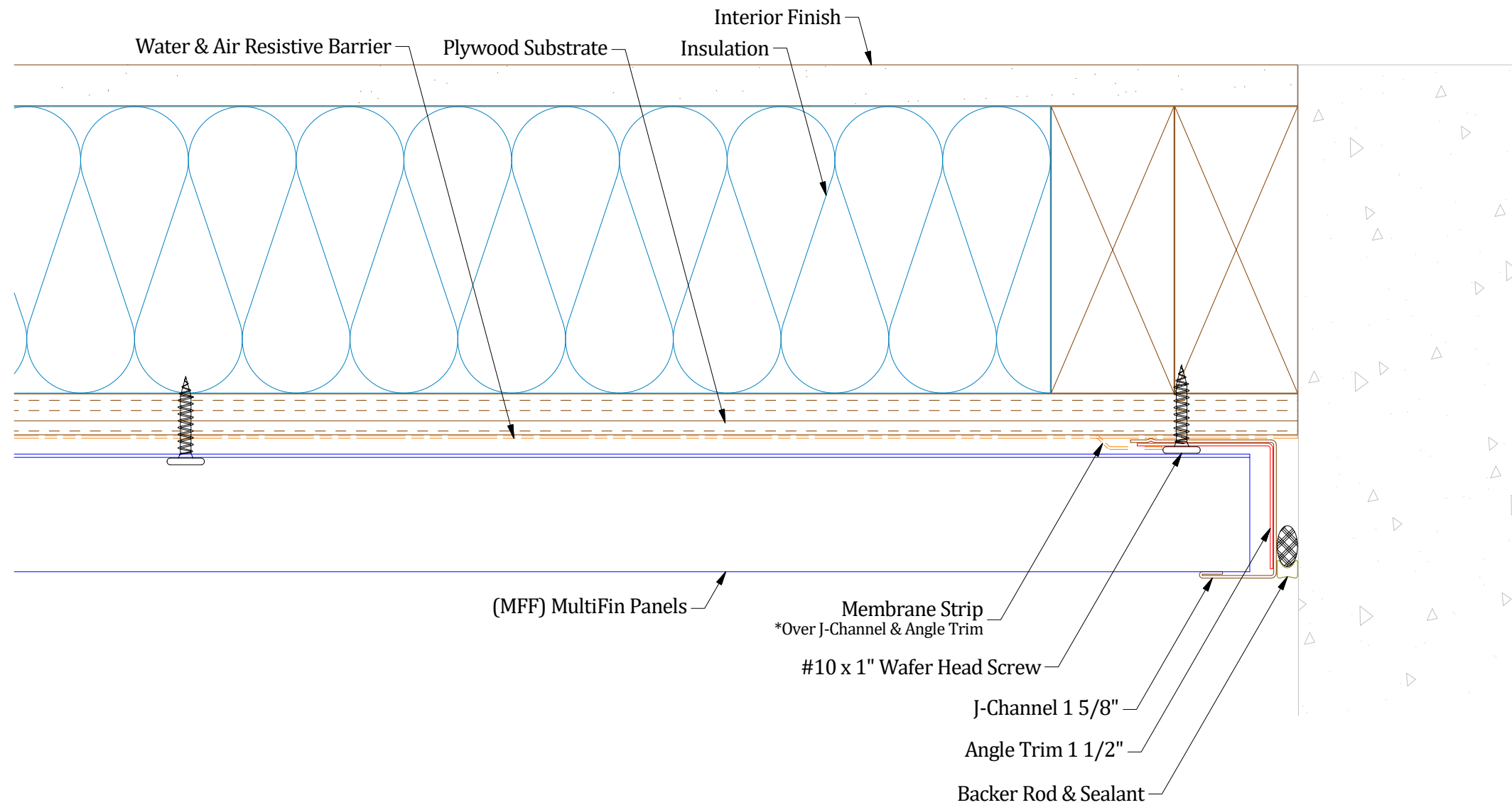

Notes:

1) * denotes color side.

ATAS International, Inc.
Sustainable Solutions For A Better Future
www.atas.com | info@atas.com
800.468.1441

DWG TITLE: Endwall Detail		DWG No.:	DWG DATE: 4/30/2026
REV. NO.	DATE	DESCRIPTION OF REVISION	BY APP
0	4/30/2026	Initial Release	M.L.P. D.S.
PANELS/PRODUCT: (MFF) MultiFin			SCALE: X : X

REV. NO.	DATE	DESCRIPTION OF REVISION	BY	APP
0	4/30/2026	Initial Release	M.L.P.	D.S.

Horizontal Panel

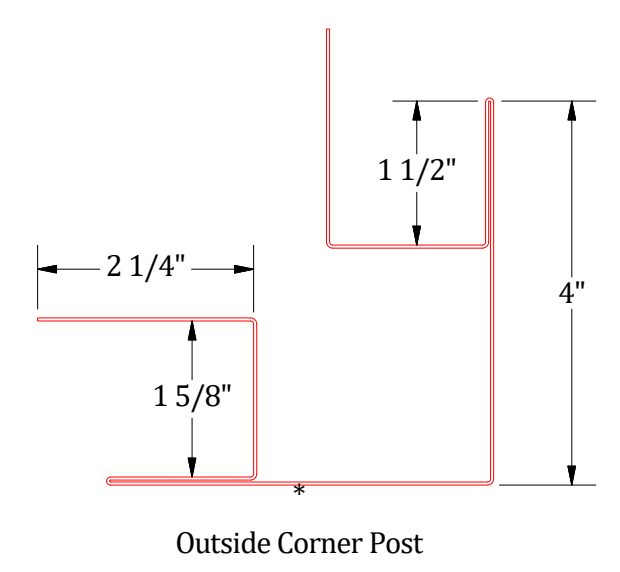
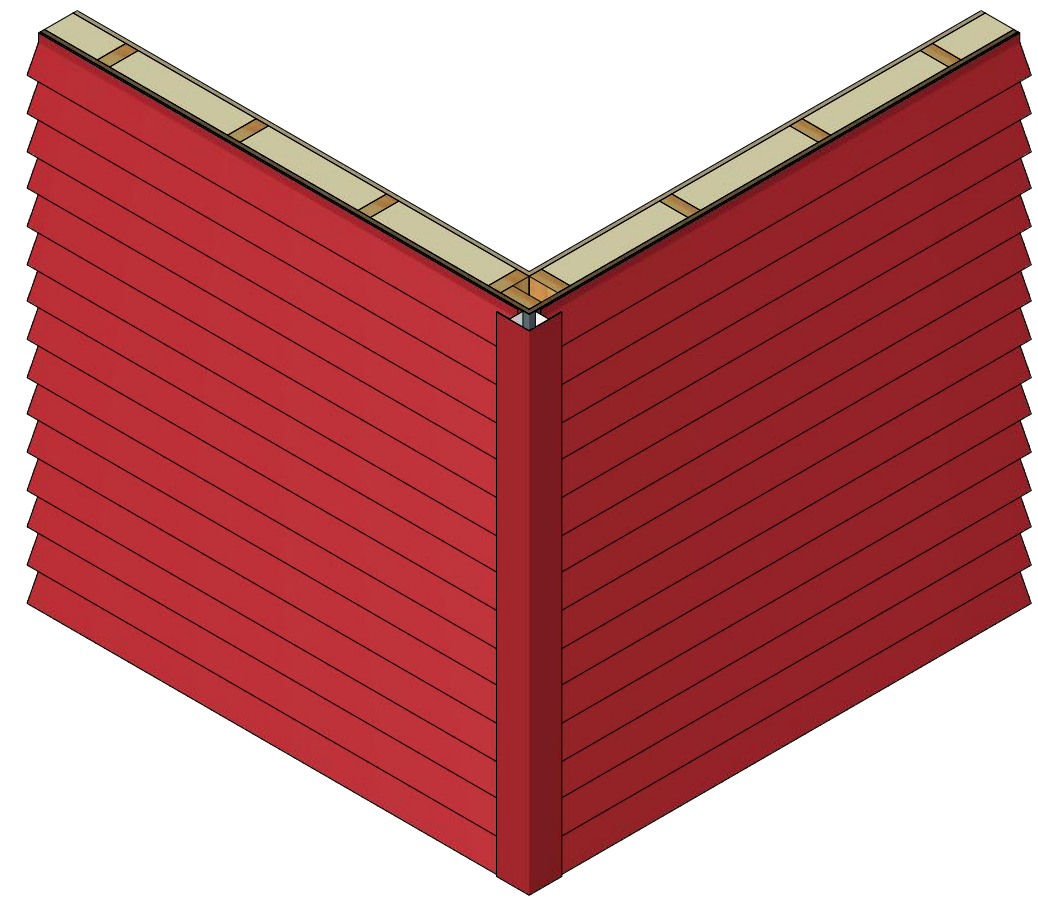
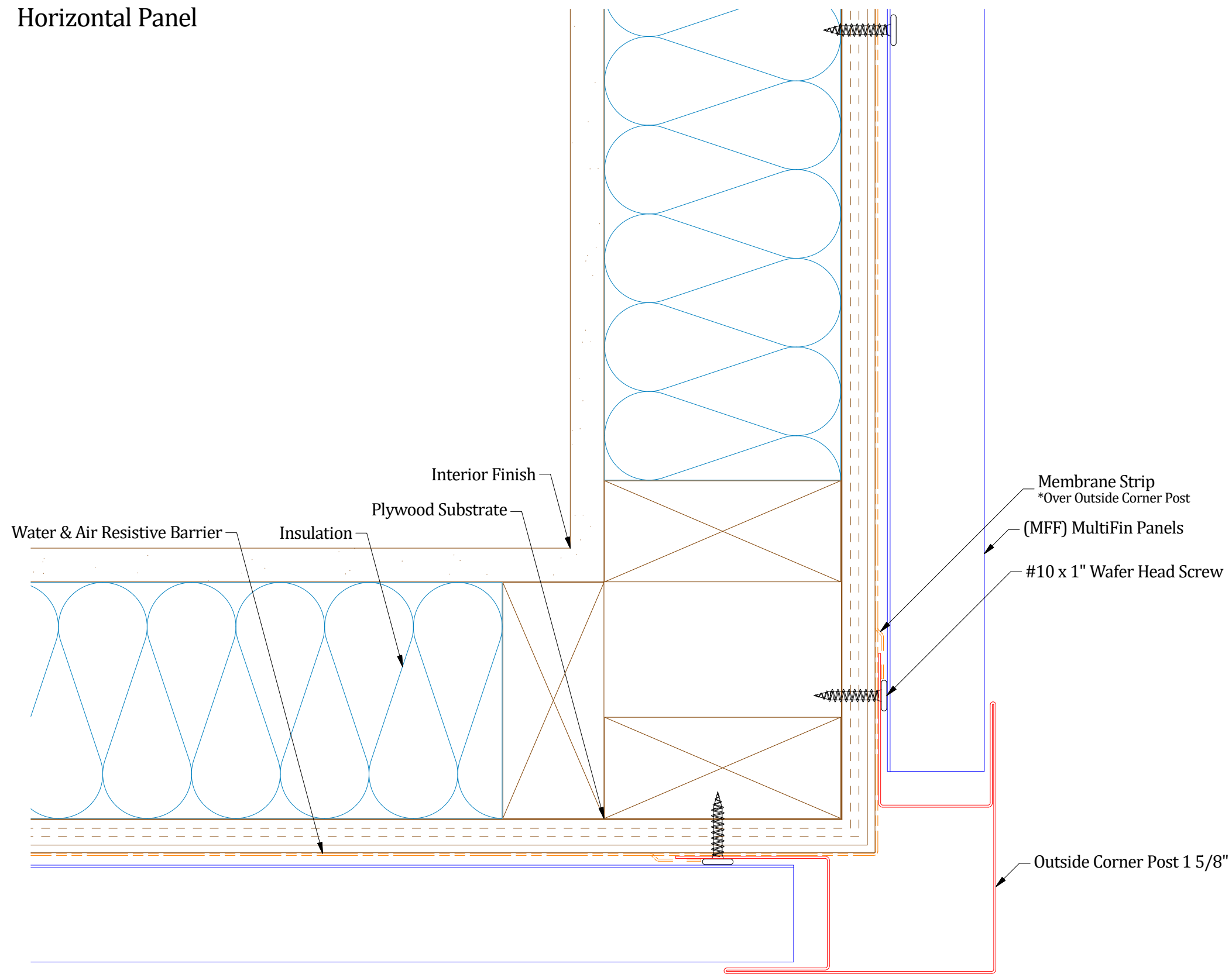

Notes:
1) * denotes color side.

ATAS International, Inc.
Sustainable Solutions For A Better Future
www.atas.com | info@atas.com
800.468.1441

REV. NO.		DATE	DESCRIPTION OF REVISION	BY	APP	DWG TITLE: Outside Corner Post Detail	
0	4/30/2026	Initial Release		M.L.P.	D.S.	DWG No.:	
						DWG DATE: 4/30/2026	
						APP BY: D.S.	
						APP DATE: 4/30/2026	
						SHEET SIZE: B	
						SCALE: X : X	

Horizontal Panel

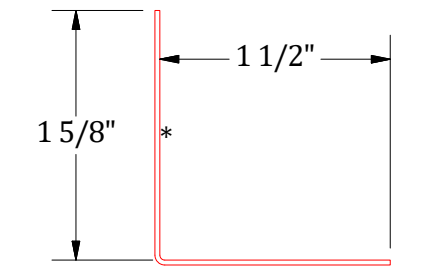
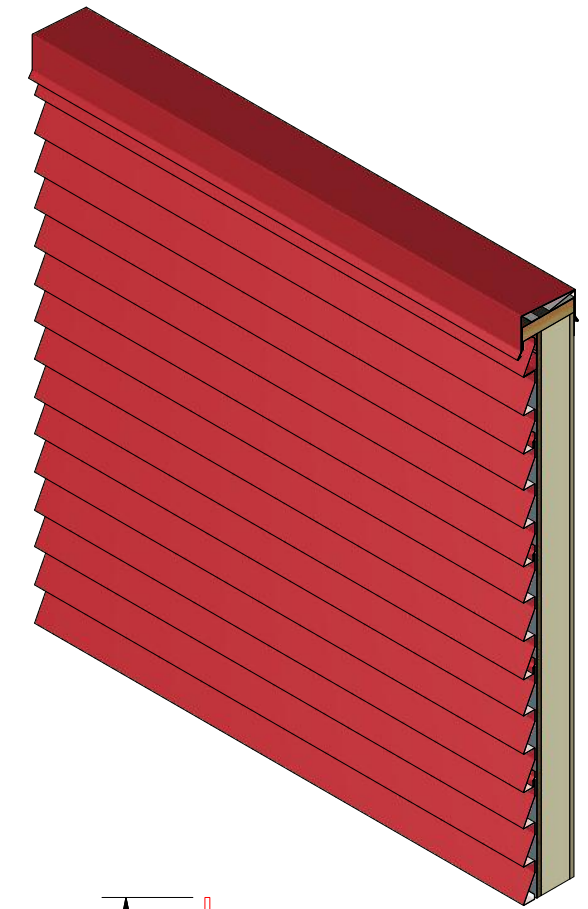
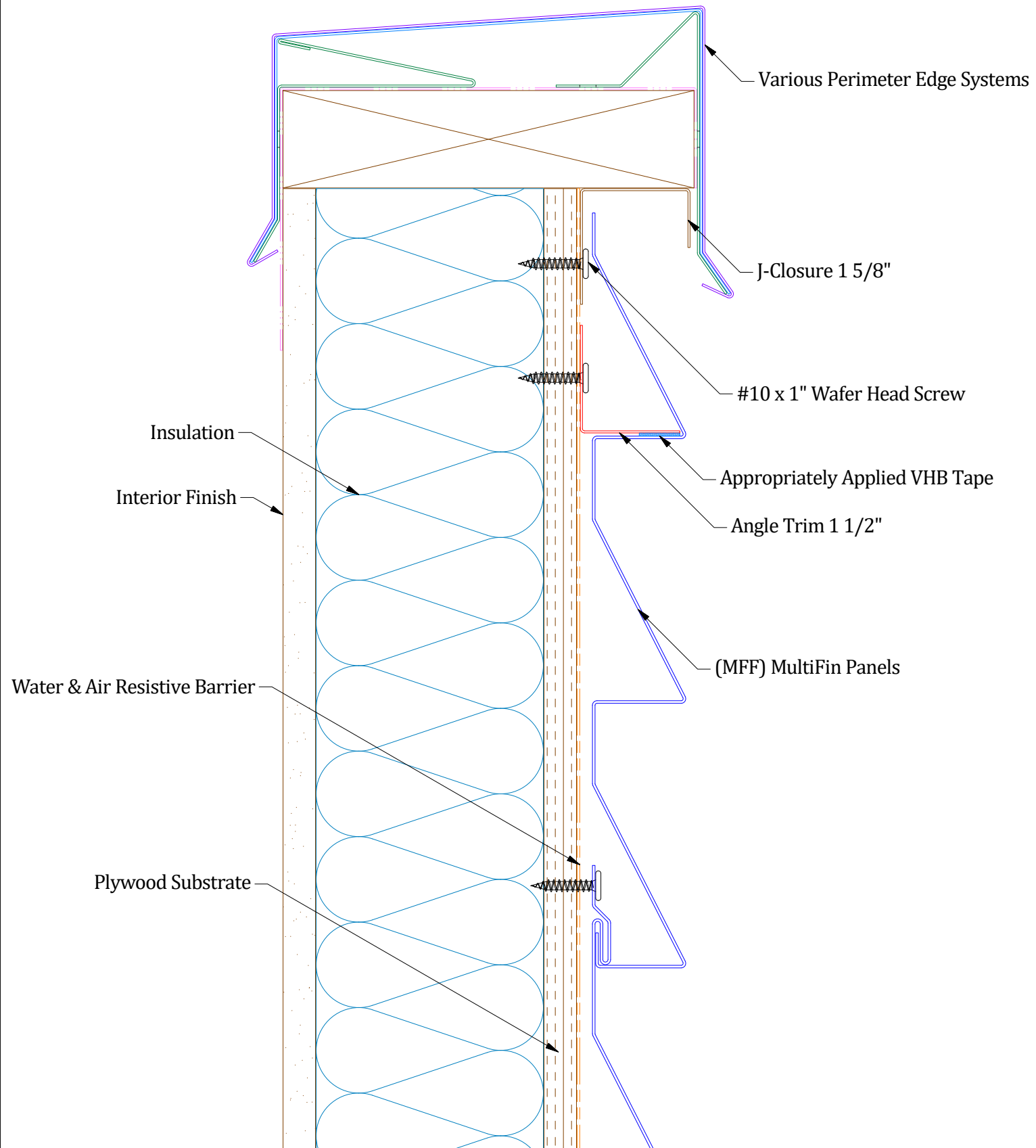

Angle Trim

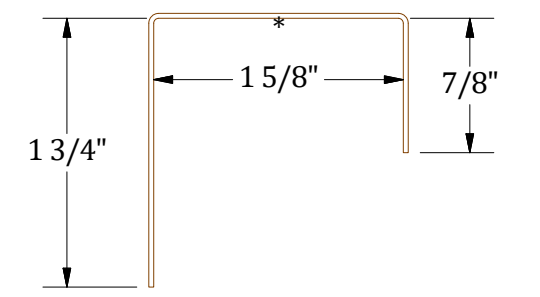

J-Closure

Notes:
 1) * denotes color side.

ATAS International, Inc.
 Sustainable Solutions For A Better Future
 www.atas.com | info@atas.com
 800.468.1441

DWG TITLE:		Top of Wall Detail	
DWG No:	M.L.P.	DWG DATE:	4/30/2026
APP BY:	D.S.	APP DATE:	4/30/2026
PANELS/PRODUCT:		SHEET SIZE:	SCALE:
(MFF) MultiFin		B	X : X

REV. NO.	DATE	DESCRIPTION OF REVISION	BY	APP
0	4/30/2026	Initial Release	M.L.P.	D.S.

Horizontal Panel

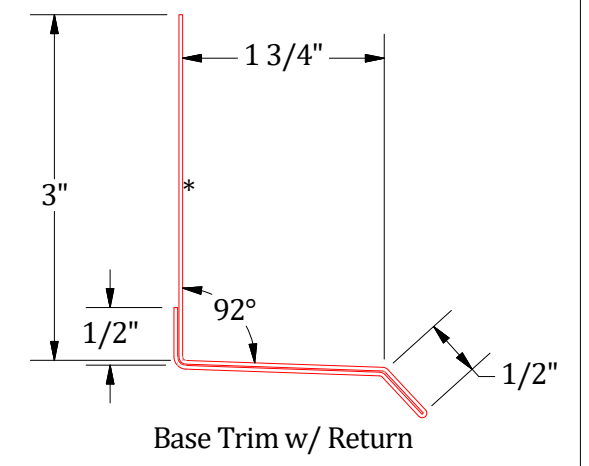
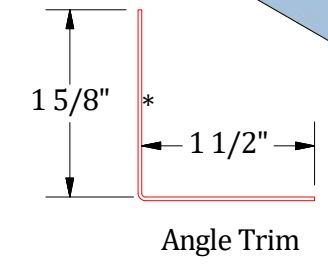
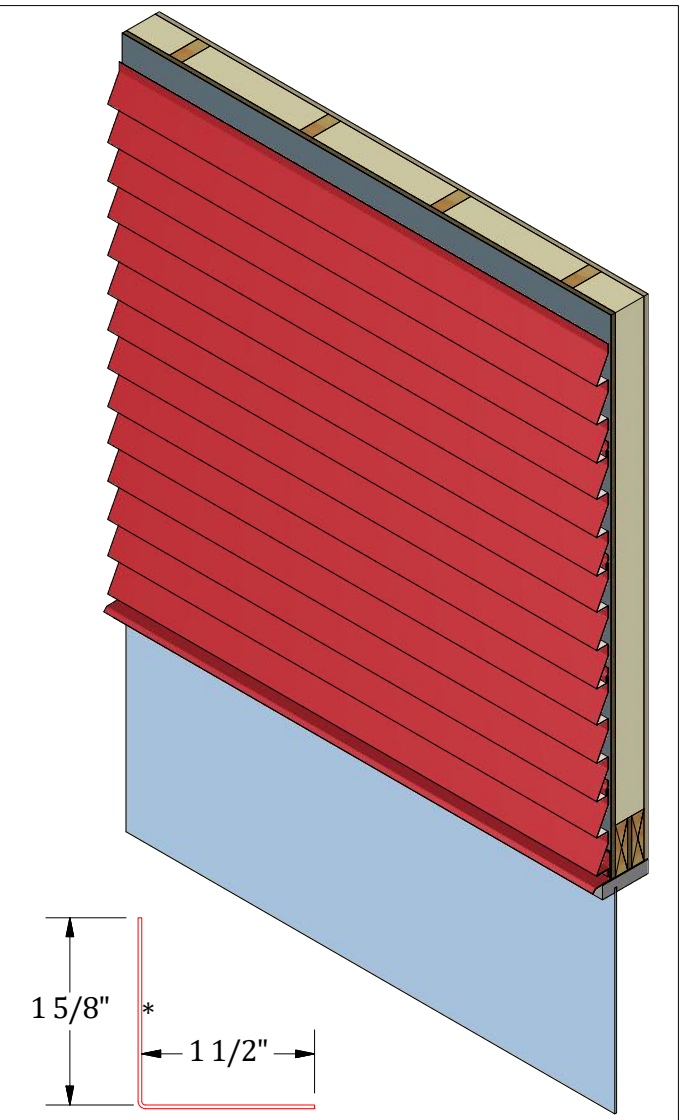
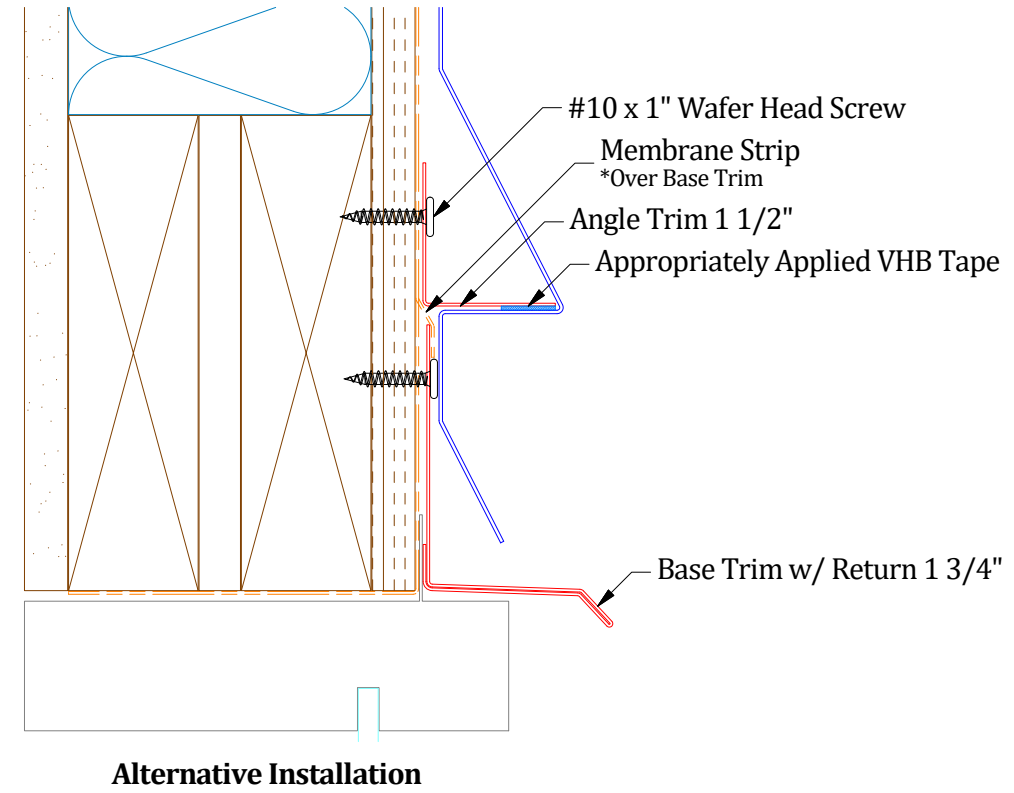
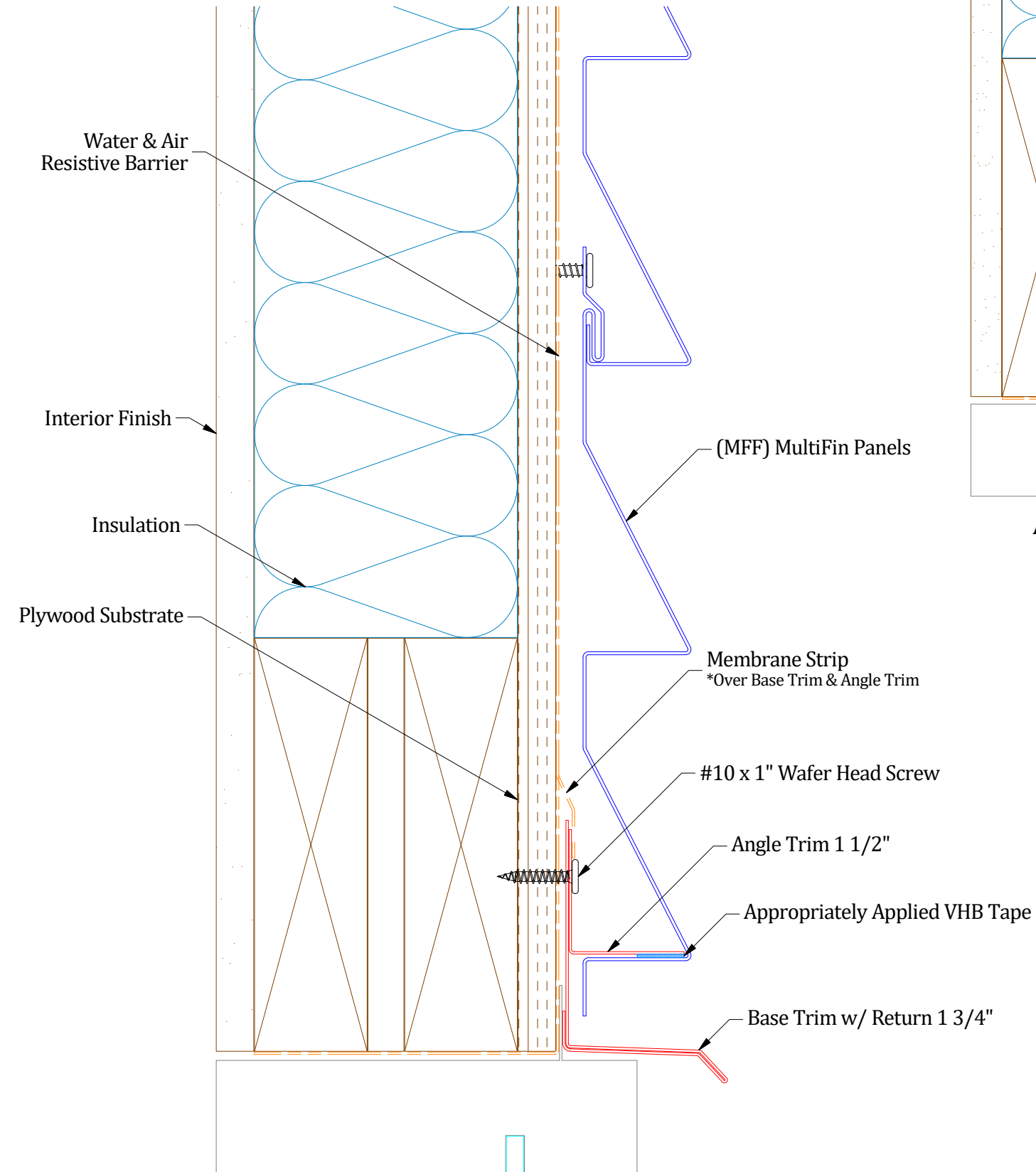

Notes:
1) * denotes color side.

ATAS International, Inc.
Sustainable Solutions For A Better Future
www.atas.com | info@atas.com
800.468.1441

DWG TITLE: Flanged Window Head Detail		DWG No.:		DWG DATE: 4/30/2026	
0	4/30/2026	Initial Release	M.L.P.	D.S.	APP DATE: 4/30/2026
REV. NO.	DATE	DESCRIPTION OF REVISION	BY	APP	SCALE: X : X
PANELS/PRODUCT: (MFF) MultiFin			SHEET SIZE: B		

Horizontal Panel

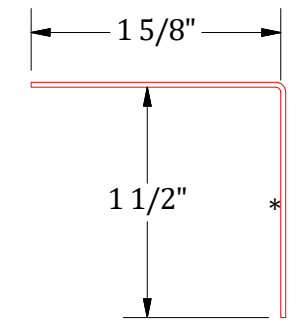
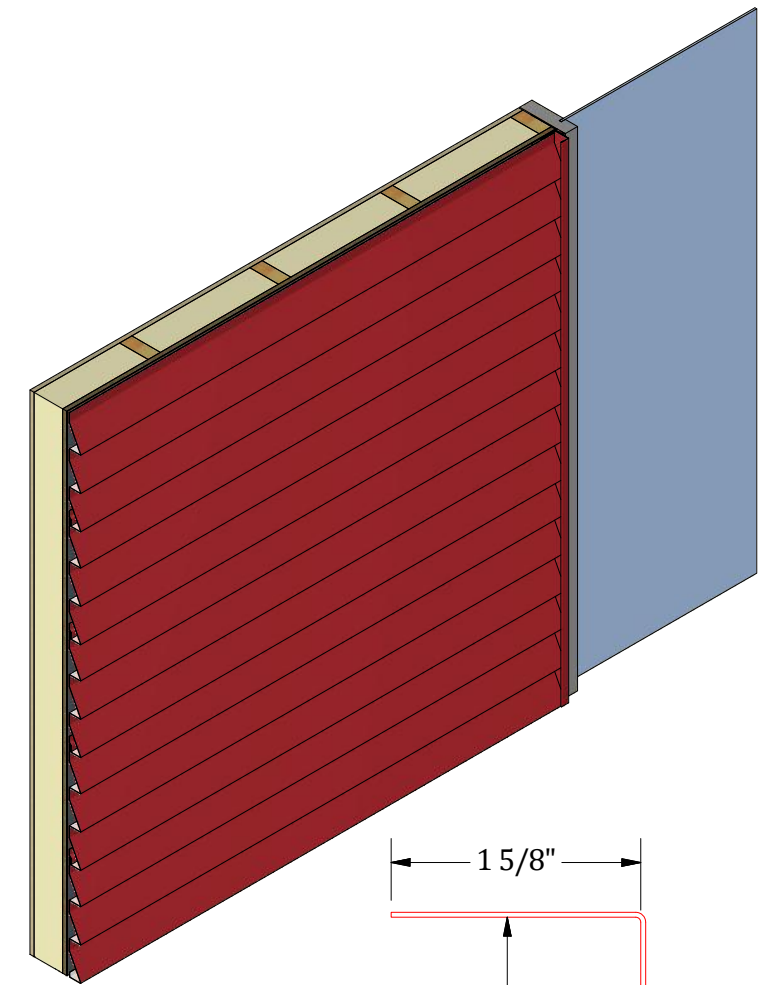
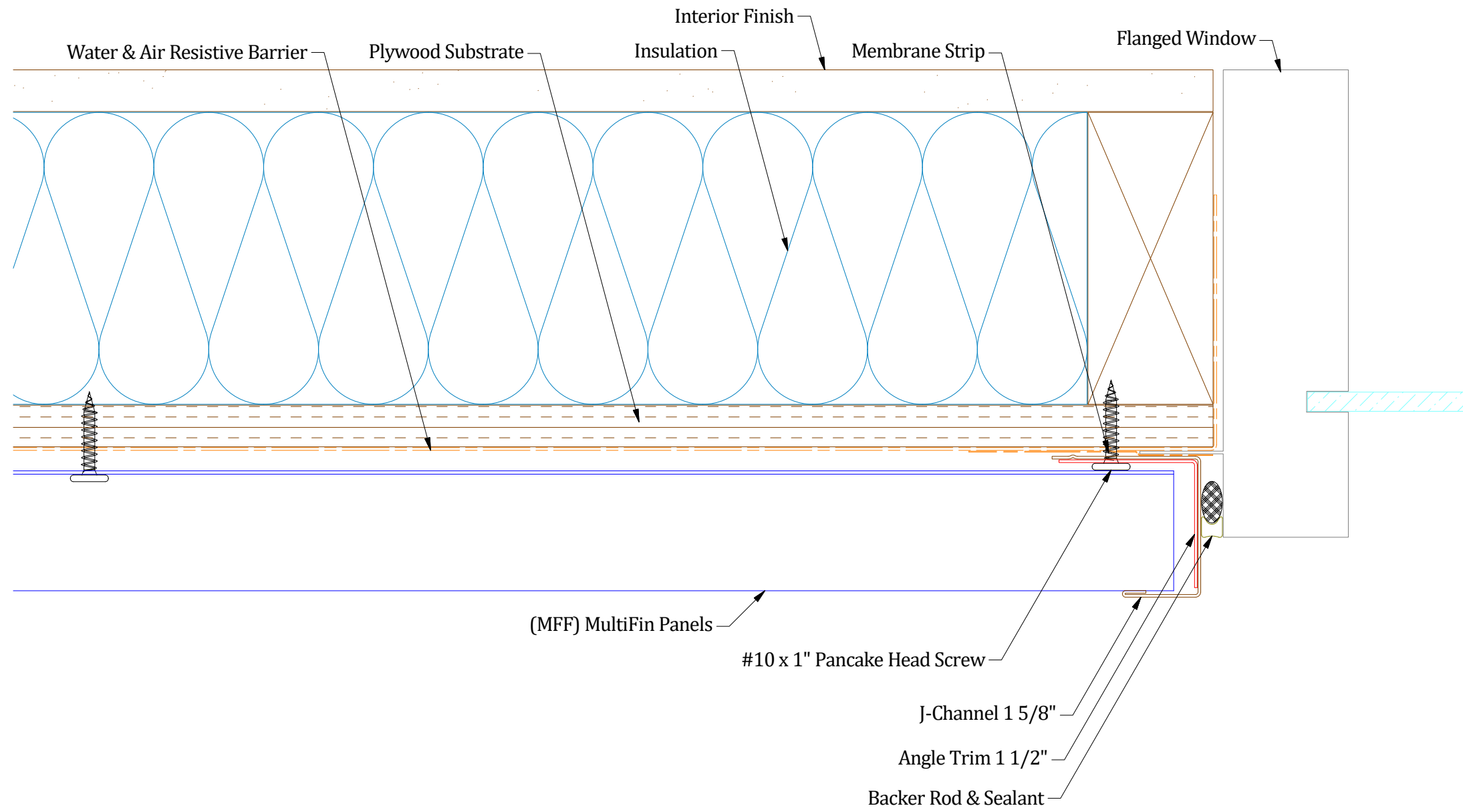

Angle Trim

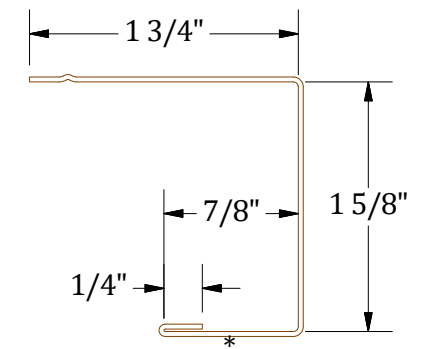

J-Channel

Notes:

1) * denotes color side.

ATAS International, Inc.
 Sustainable Solutions For A Better Future
 www.atas.com | info@atas.com
 800.468.1441

Flanged Window Jamb Detail

REV. NO.	DATE	DESCRIPTION OF REVISION	BY	APP	DWG No.	DWG DATE:
0	4/30/2026	Initial Release	M.L.P.	D.S.		4/30/2026
					PANELS/PRODUCT:	APP DATE:
					(MFF) MultiFin	4/30/2026
					SHEET SIZE:	SCALE:
					B	X : X

Horizontal Panel

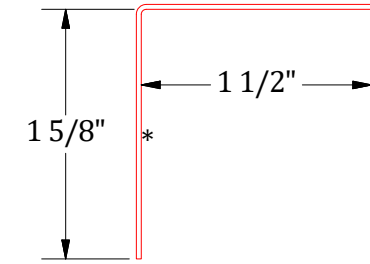
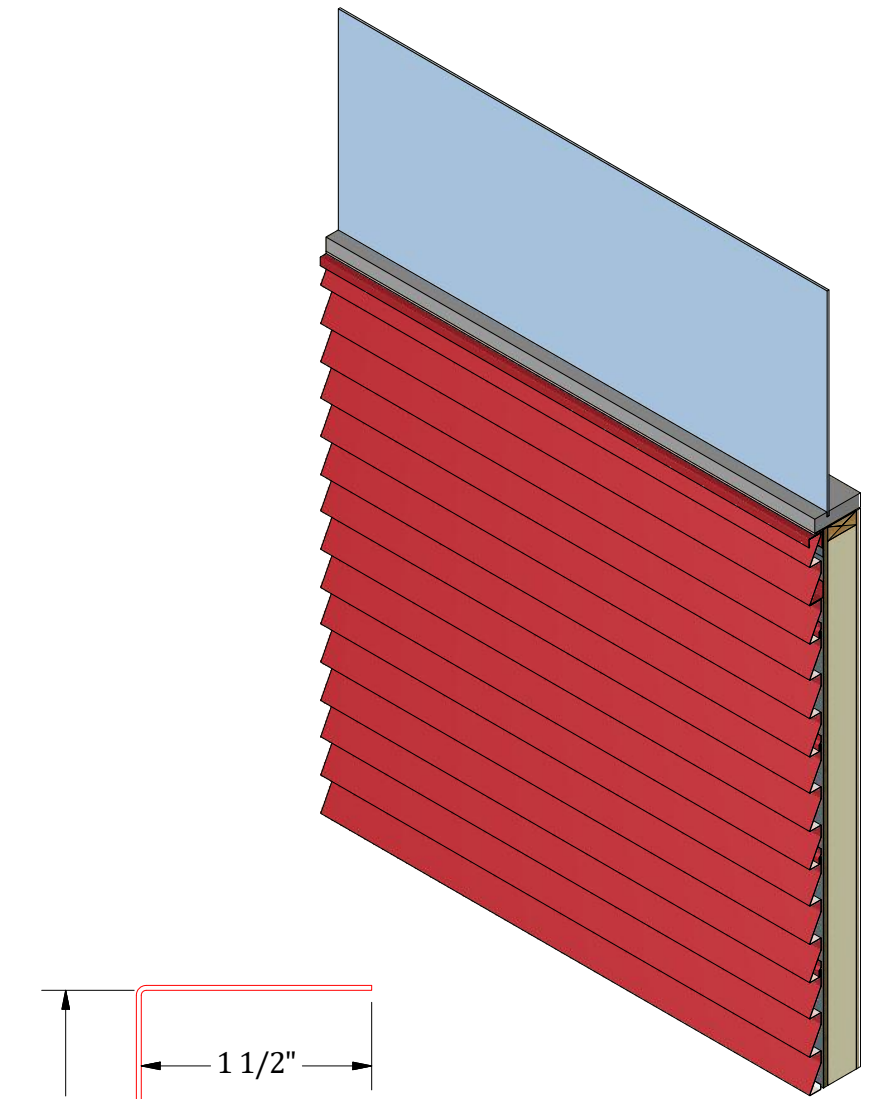
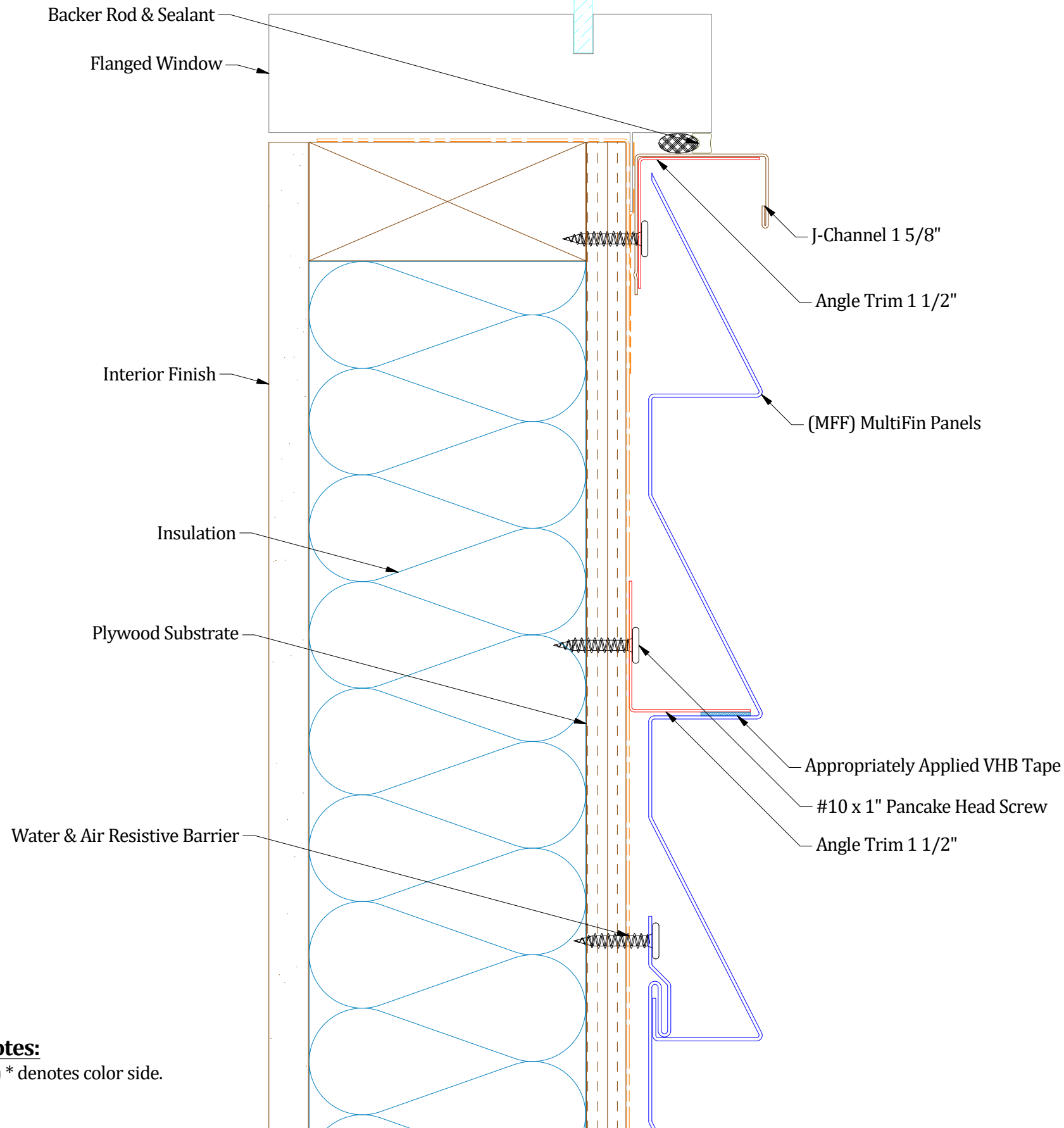

Angle Trim

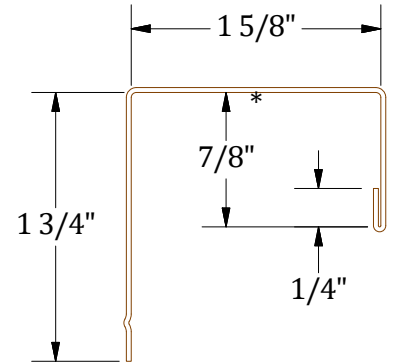

J-Channel

Notes:

1) * denotes color side.

ATAS **ATAS International, Inc.**
 Sustainable Solutions For A Better Future
 www.atas.com | info@atas.com
 800.468.1441

REV. NO.	DATE	DESCRIPTION OF REVISION	BY	APP	PANELS/PRODUCT:	DWG No.	DWG DATE:
0	4/30/2026	Initial Release	M.L.P.	D.S.	(MFF) MultiFin		4/30/2026
							APP DATE: 4/30/2026
							SHEET SIZE: B
							SCALE: X : X

Flanged Window Sill Detail

Horizontal Panel

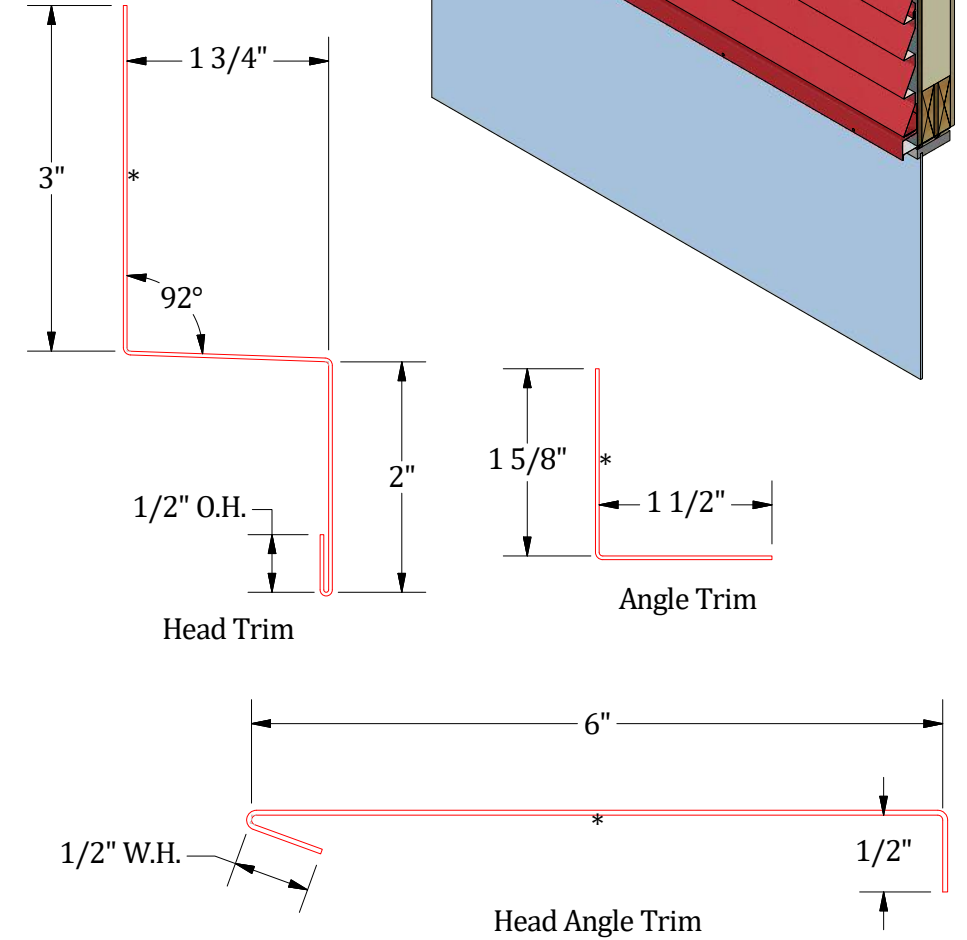
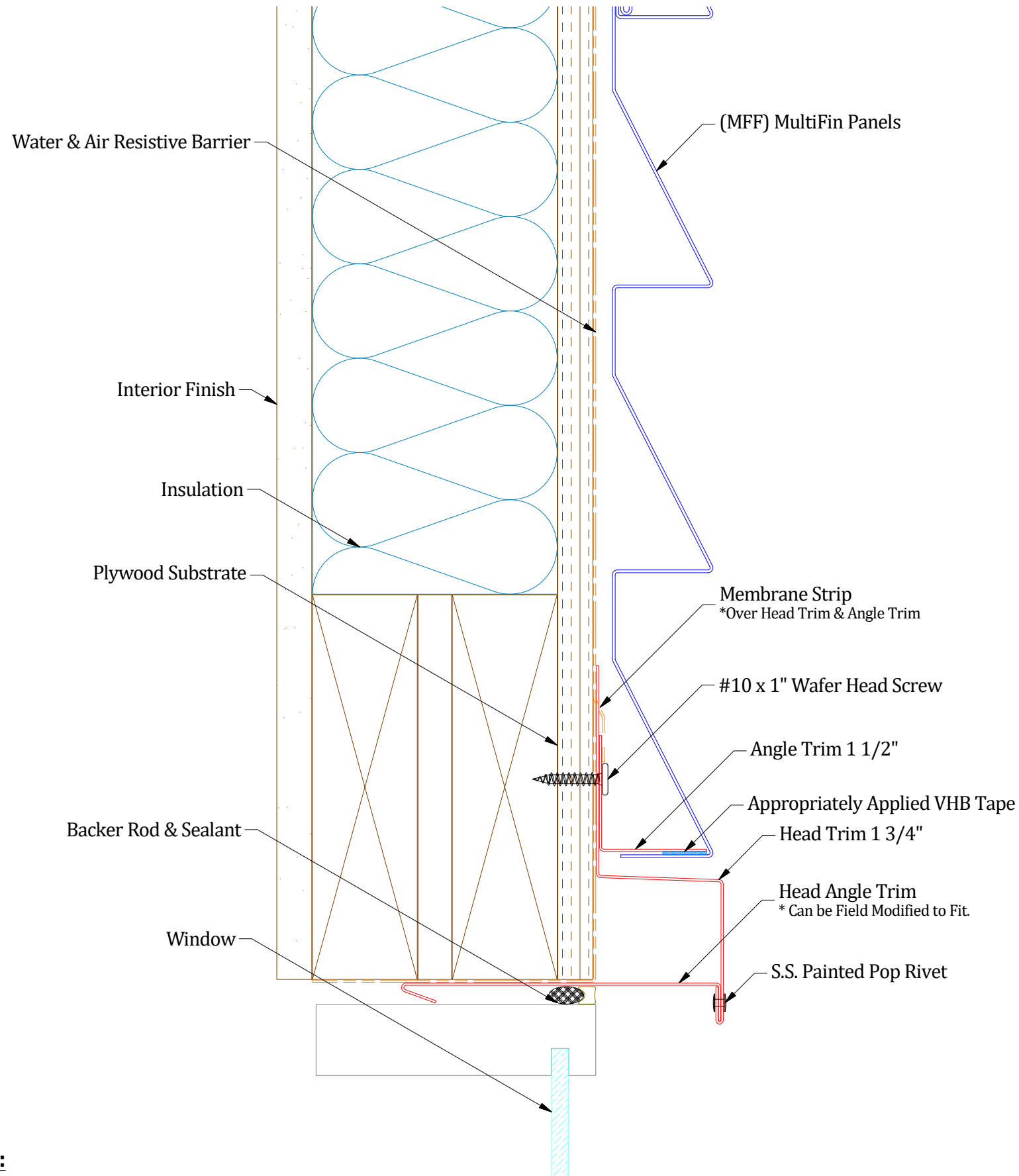

Notes:

1) * denotes color side.

ATAS International, Inc.
Sustainable Solutions For A Better Future
www.atas.com | info@atas.com
800.468.1441

DWG TITLE: Window Head Detail		DWG No.:	DWG DATE: 4/30/2026
0	4/30/2026	Initial Release	M.L.P. D.S.
REV. NO.	DATE	DESCRIPTION OF REVISION	BY APP
PANELS/PRODUCT: (MFF) MultiFin			APP BY: D.S. APP DATE: 4/30/2026 SHEET SIZE: B SCALE: X : X

0	4/30/2026	Initial Release	M.L.P.	D.S.
REV. NO.	DATE	DESCRIPTION OF REVISION	BY	APP

Horizontal Panel

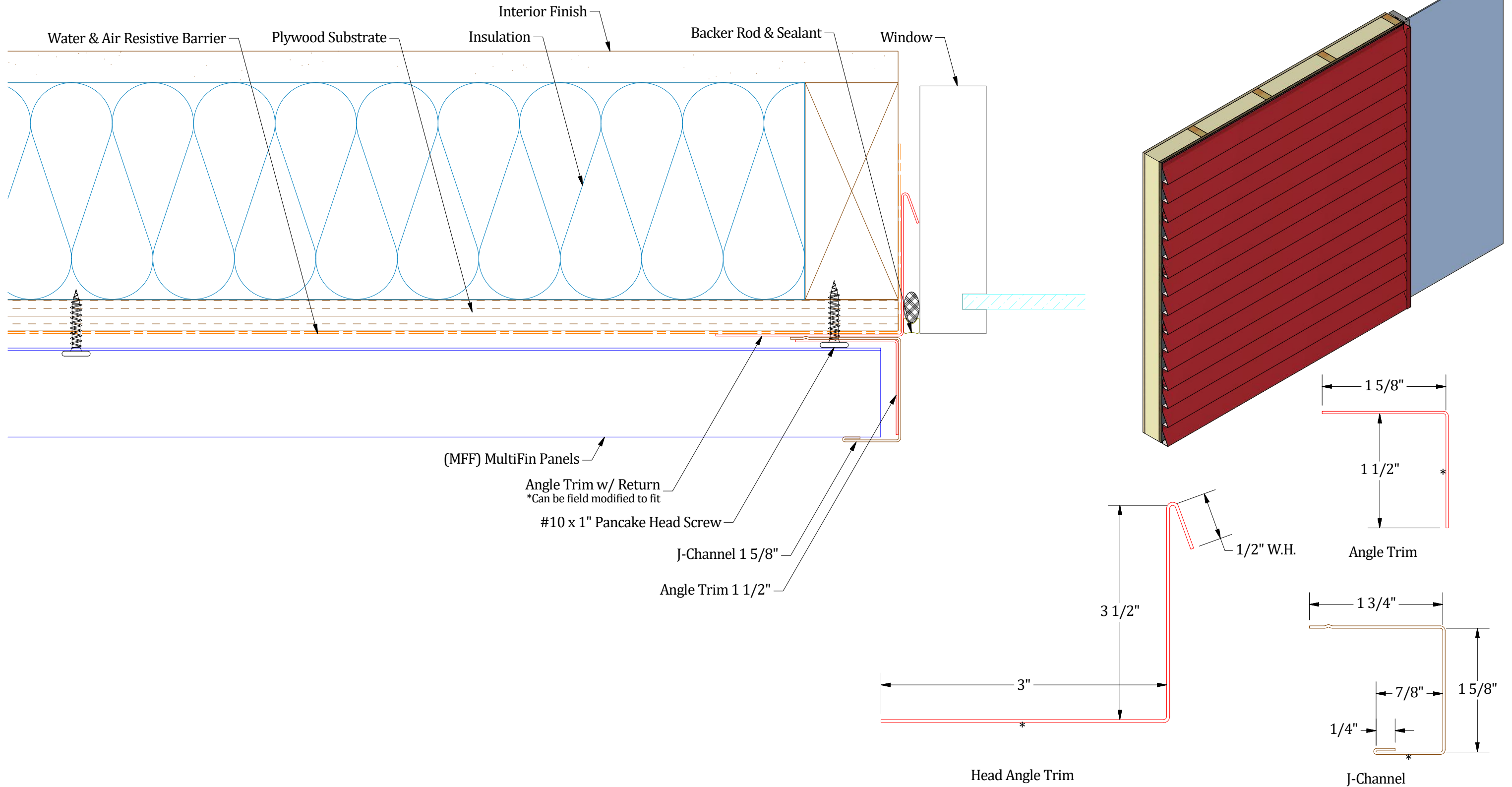

Notes:

1) * denotes color side.

ATAS International, Inc.
 Sustainable Solutions For A Better Future
 www.atas.com | info@atas.com
 800.468.1441

REV. NO.		DATE	DESCRIPTION OF REVISION	BY	APP	DWG TITLE: Window Jamb Detail	
0	4/30/2026	Initial Release		M.L.P.	D.S.	DWG No. (MFF) MultiFin	
DWG BY: M.L.P. DATE: 4/30/2026						APP BY: D.S. DATE: 4/30/2026	
SHEET SIZE: B						SCALE: X : X	

Horizontal Panel

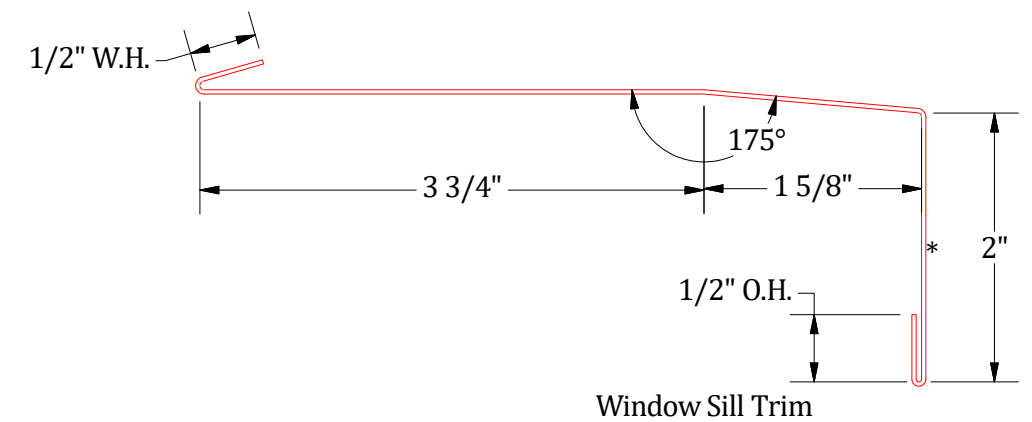
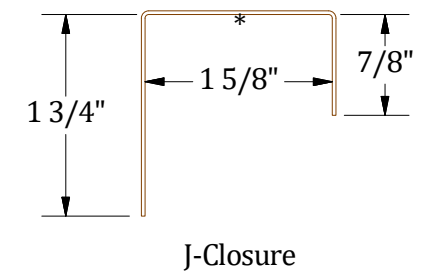
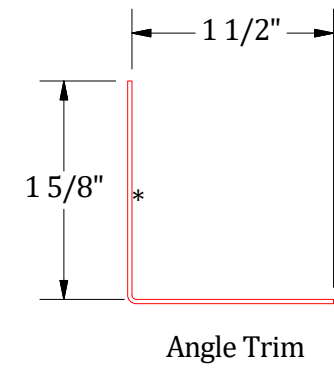
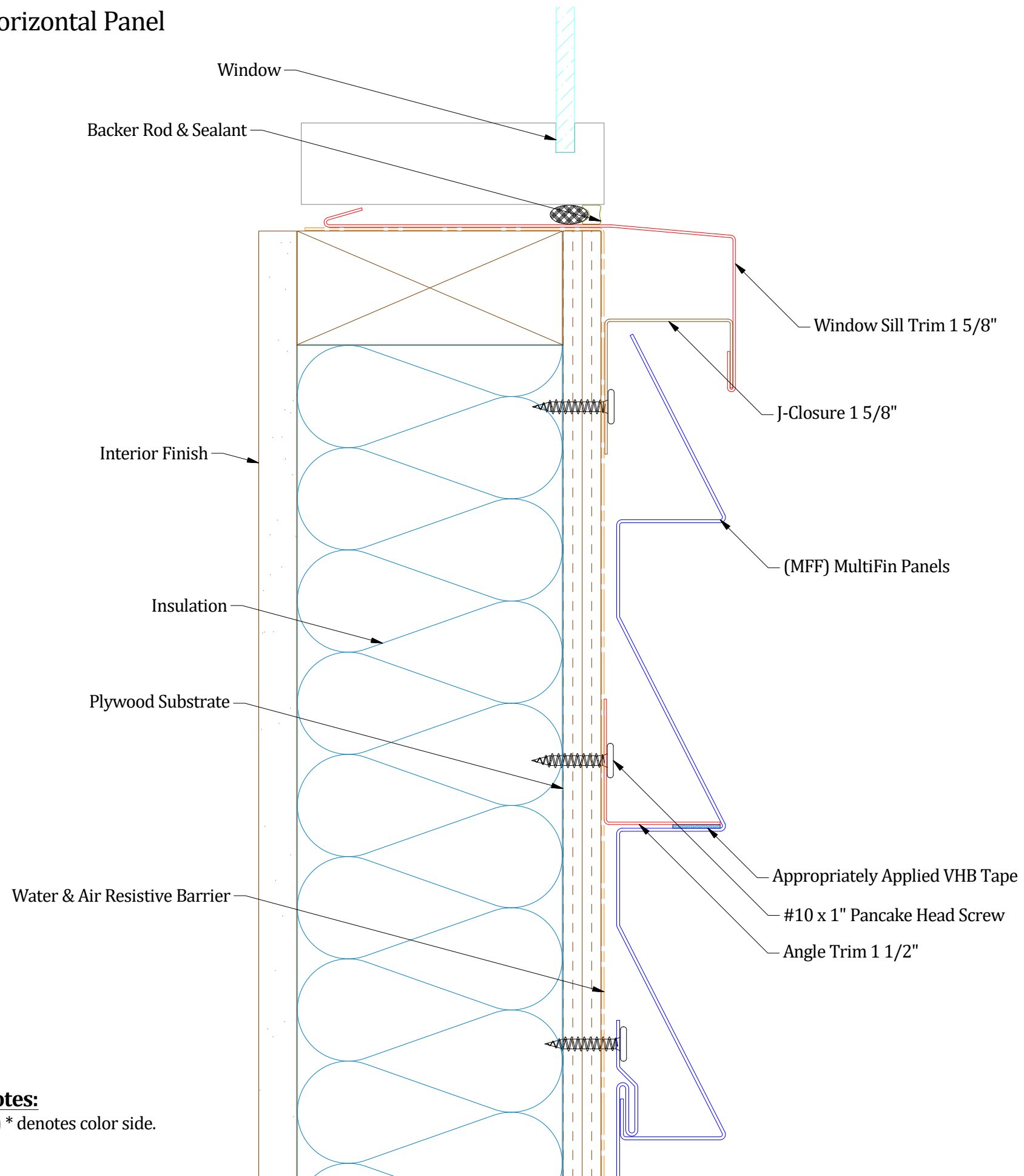

ATAS International, Inc.
 Sustainable Solutions For A Better Future
 www.atas.com | info@atas.com
 800.468.1441

Notes:
 1) * denotes color side.

REV. NO.	DATE	DESCRIPTION OF REVISION	BY	APP	DATE	SCALE
0	4/30/2026	Initial Release	M.L.P.	D.S.	4/30/2026	X : X

DWG TITLE: **Window Sill Detail**

DWG No: (MFF) MultiFin

APP BY: D.S. DATE: 4/30/2026

SHEET SIZE: B